

MODEL PFW-X/PFWC-X 100 THRU 800 INSTALLATION INSTRUCTIONS

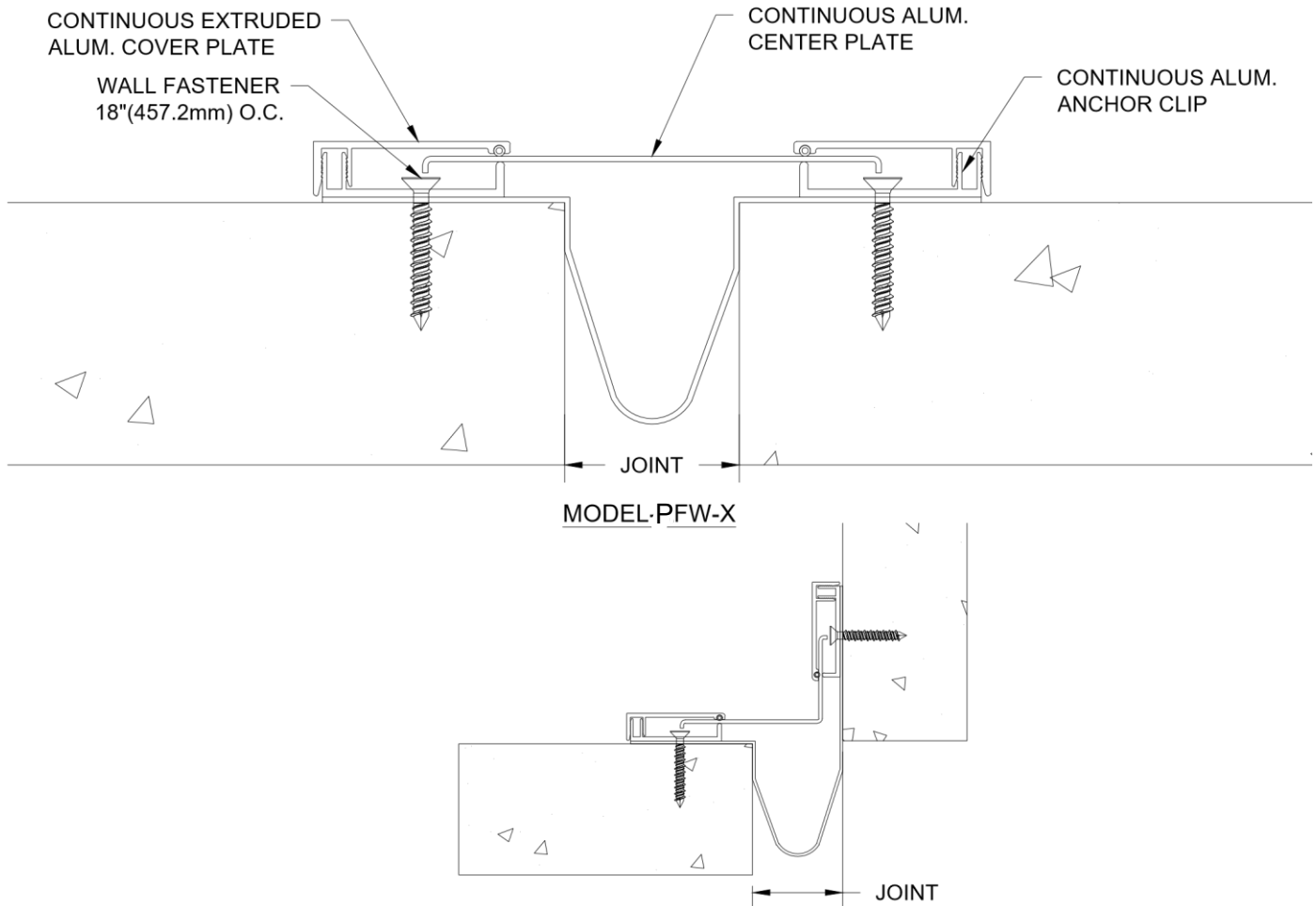

IMPORTANT INFORMATION

MODEL-PFWC-X

Prior to the commencement of Installation, all materials MUST be inspected for Damage. Any damage must be reported to CONSTRUCTION SPECIALTIES, INC., as soon as possible, so that replacement materials may be furnished without delay.

All work must be completed as per Architect's Approved "Shop Drawings", and in accordance with these Installation Instructions. When installation is complete, all materials must be protected from damage until the Architect's FINAL INSPECTION.

All materials should be arranged in the order that they are to be installed. All hardware required for each portion of the work should be placed with the appropriate materials.

Please review all Approved Shop Drawings and this Document to familiarize yourself with all the details and components of this assembly.

IMPORTANT:

READ THROUGH ALL INSTRUCTIONS PRIOR TO STARTING INSTALLATION

11/29/11

Notes:

Before beginning installation, review the architectural drawings and approved Construction Specialties Inc. shop drawings to familiarize yourself with the appropriate joint cover models and locations.

Check all the joint cover components to confirm that the correct joint cover model and size have been received. Also, check for materials that may have been damaged during shipping. Report all incorrect and/or damaged components to P/S at 800-233-8493.

Read through all the steps of these instructions prior to beginning work.

Remove protective coating from all parts **before** installation.

STEP 1

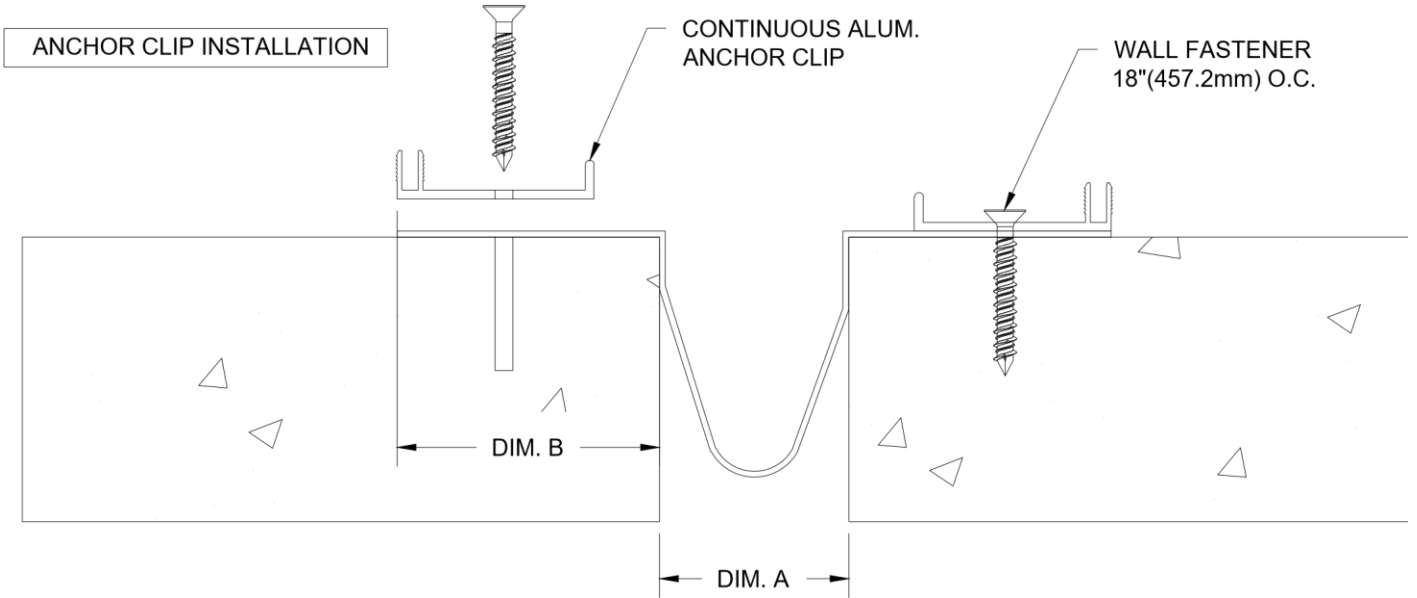

FRAME LOCATION DIMENSIONS		
DIM. A	DIM. B	DIM. C
1" [25.4mm]	1-7/8" [48.4mm]	2-5/8" [66.7mm]
2" [50.8mm]	2-3/4" [70.4mm]	3-5/8" [92.1mm]
3" [76.2mm]	3-3/4" [95.64mm]	5-7/8" [149.2mm]
4" [101.6mm]	3-3/4" [95.64mm]	5-7/8" [149.2mm]
5" [127mm]	3-7/8" [98.4mm]	5-7/8" [149.2mm]
6" [127mm]	3-7/8" [98.4mm]	5-7/8" [149.2mm]
7" [177.8mm]	5" [127mm]	5-7/8" [149.2mm]
8" [203.2mm]	5" [127mm]	5-7/8" [149.2mm]

MODEL-PFW-X

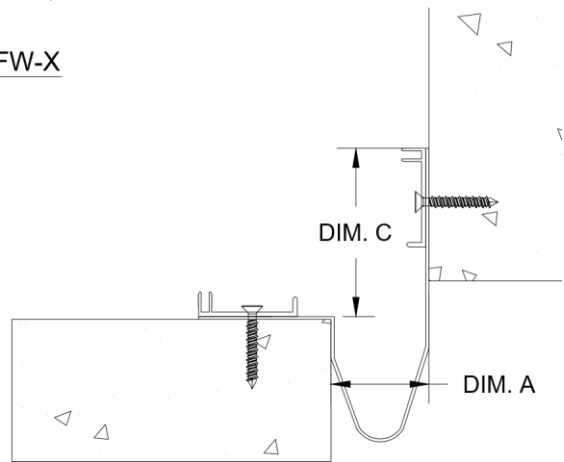

MODEL-PFWC-X

Note:

-If a P/S Fire Barrier is to be installed in the joint, please review the Fire Barrier Installation Instructions supplied, and if required install the Fire Barrier **BEFORE** installation of P/S Expansion Joint Cover.

-Begin installation of Expansion Wall Joint Cover by installing the Vapor Barrier first. Please review the Vapor Barrier Instructions supplied.

- 1.1) Begin installation of the Anchor Clips by snapping a plumb vertical chalk line at Dim. B & Dim. C. Note: The Anchor Clips must be installed plumb and square with chalk line to facilitate proper alignment and engagement of the Cover Plate. See Details above.
- 1.2) Attach the Anchor Clips to the wall at 18"(457.2mm) o.c. maximum, with the appropriate P/S supplied anchors.
- 1.3) Repeat the installation procedures for the opposite side of the joint if required.

STEP 2

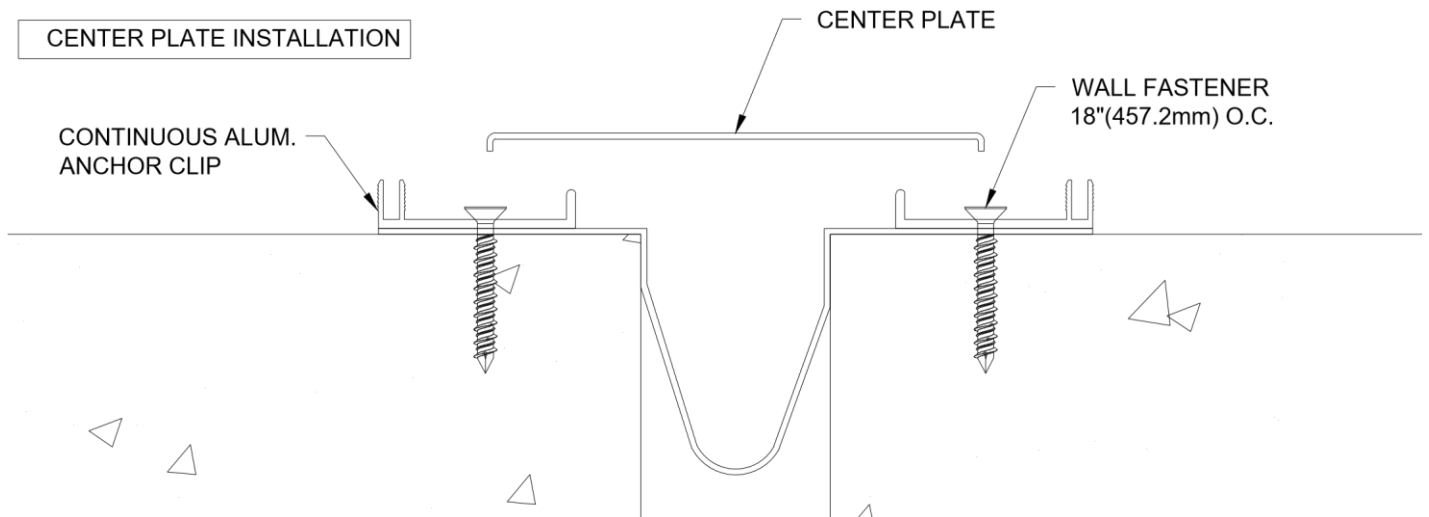

MODEL-PFW-X

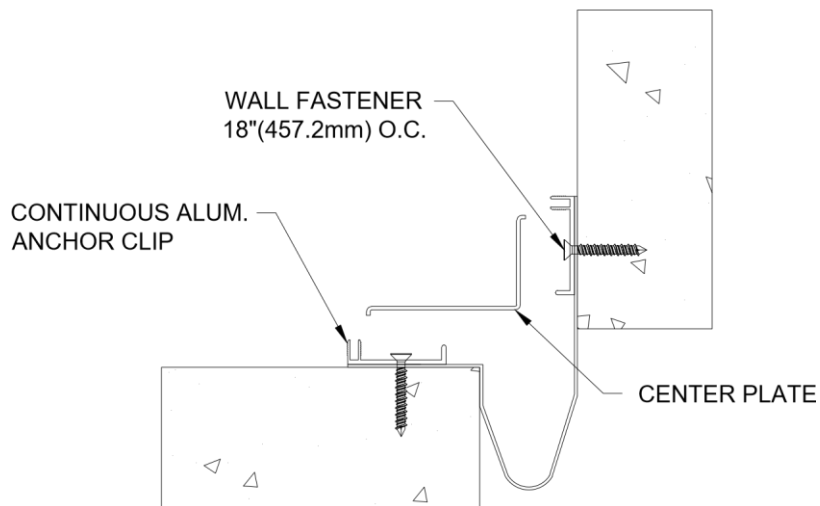

MODEL-PFWC-X

- 2.1) Begin installation of the Center Plate by first cutting the Plate to length as needed.
- 2.2) Place Center Plate on top of the Anchor Clips, keeping it centered over the joint, as shown above.

STEP 3

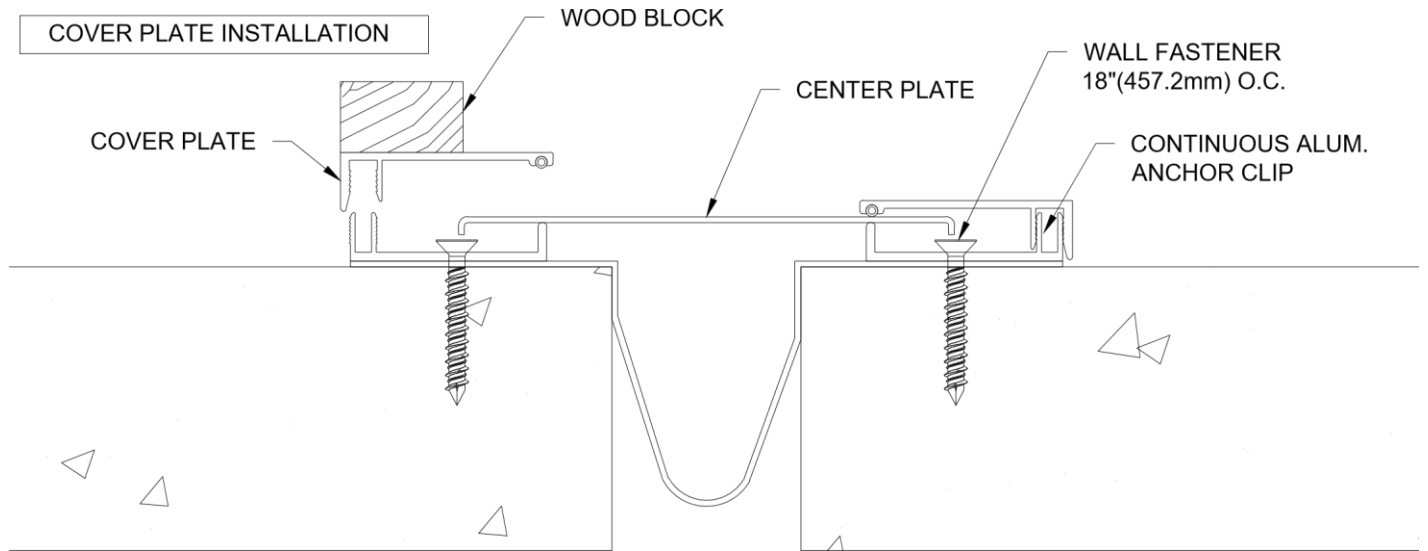

MODEL-PFW-X

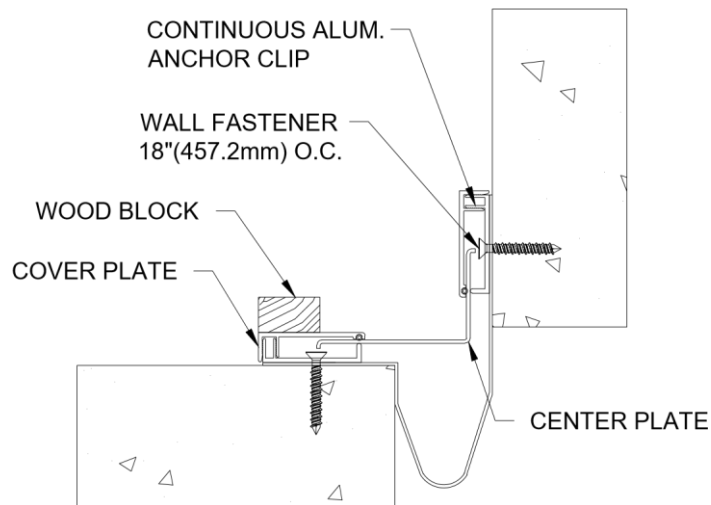

MODEL-PFWC-X

- 3.1) Begin installation of the Cover Plate to anchor clips by aligning one end of a length of Cover Plate with the end of the installed anchor clips.
- 3.2) Place a wood block on top of the Cover Plate. While holding the Cover Plate somewhat level, use a rubber mallet to strike the wood block. (Note: Do not hammer directly onto the Cover Plates as this may cause damage to the Cover Plate.)
- 3.3) Work down along the length of the Cover Plate driving the Cover Plate approx. half onto the Anchor Clips. Then return and drive the Cover Plate the remainder of the way in until the Cover Plate is seated flush with the wall.
- 3.4) Repeat these procedures for the opposite side of the joint and for any additional lengths of Cover Plate.

STEP 4

COMPLETE INSTALLATION

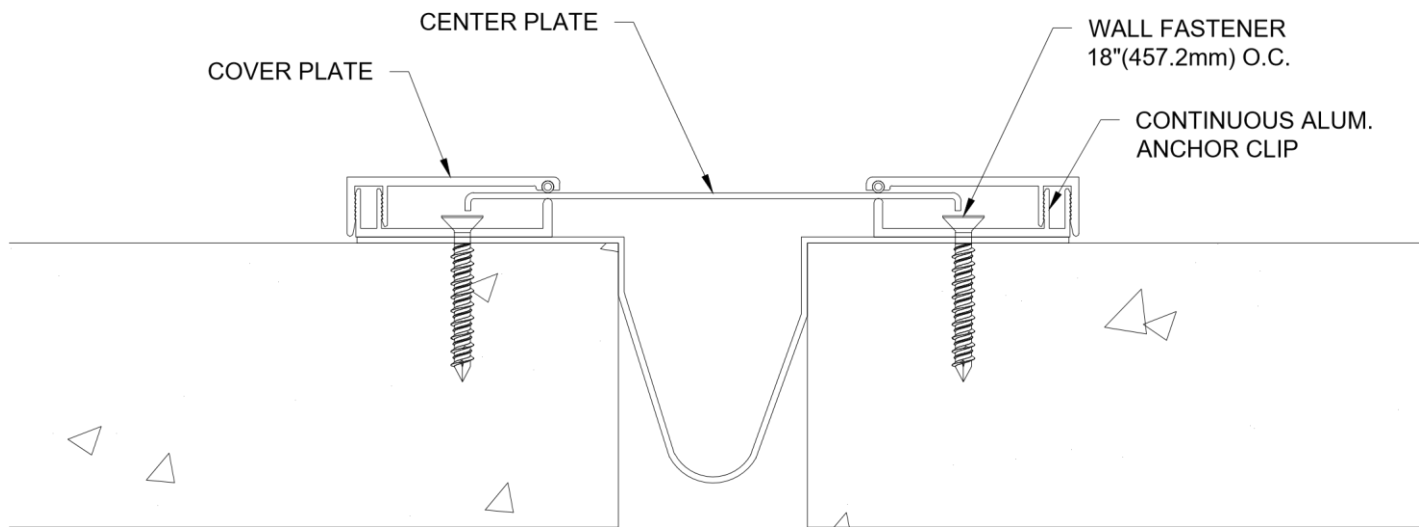

MODEL-PFW-X

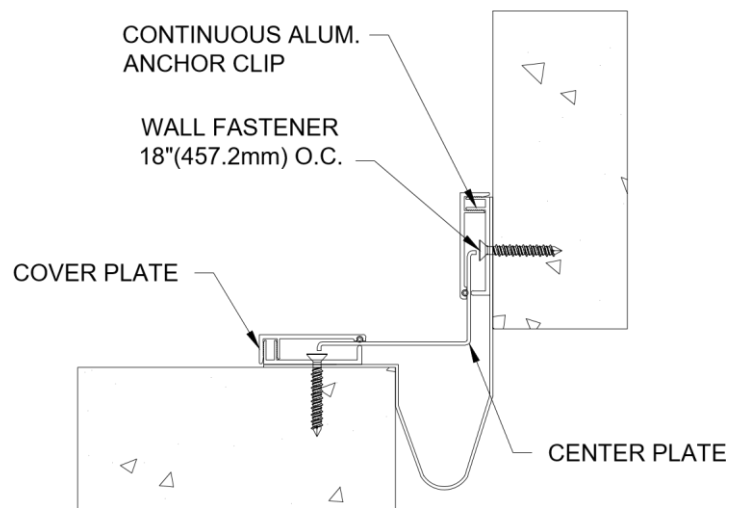

MODEL-PFWC-X

- 4.1) When installation of the P/S Wall Expansion Joint Cover has been completed, remove all residue and foreign matter from the area and joint cover.
- 4.2) Clean the P/S Joint Cover and adjoining surfaces with proper cleaner.
- 4.3) Protect the Joint Cover until the Architect's final inspection.