

MODEL PSFW/PSCW 400-1600 INSTALLATION INSTRUCTIONS

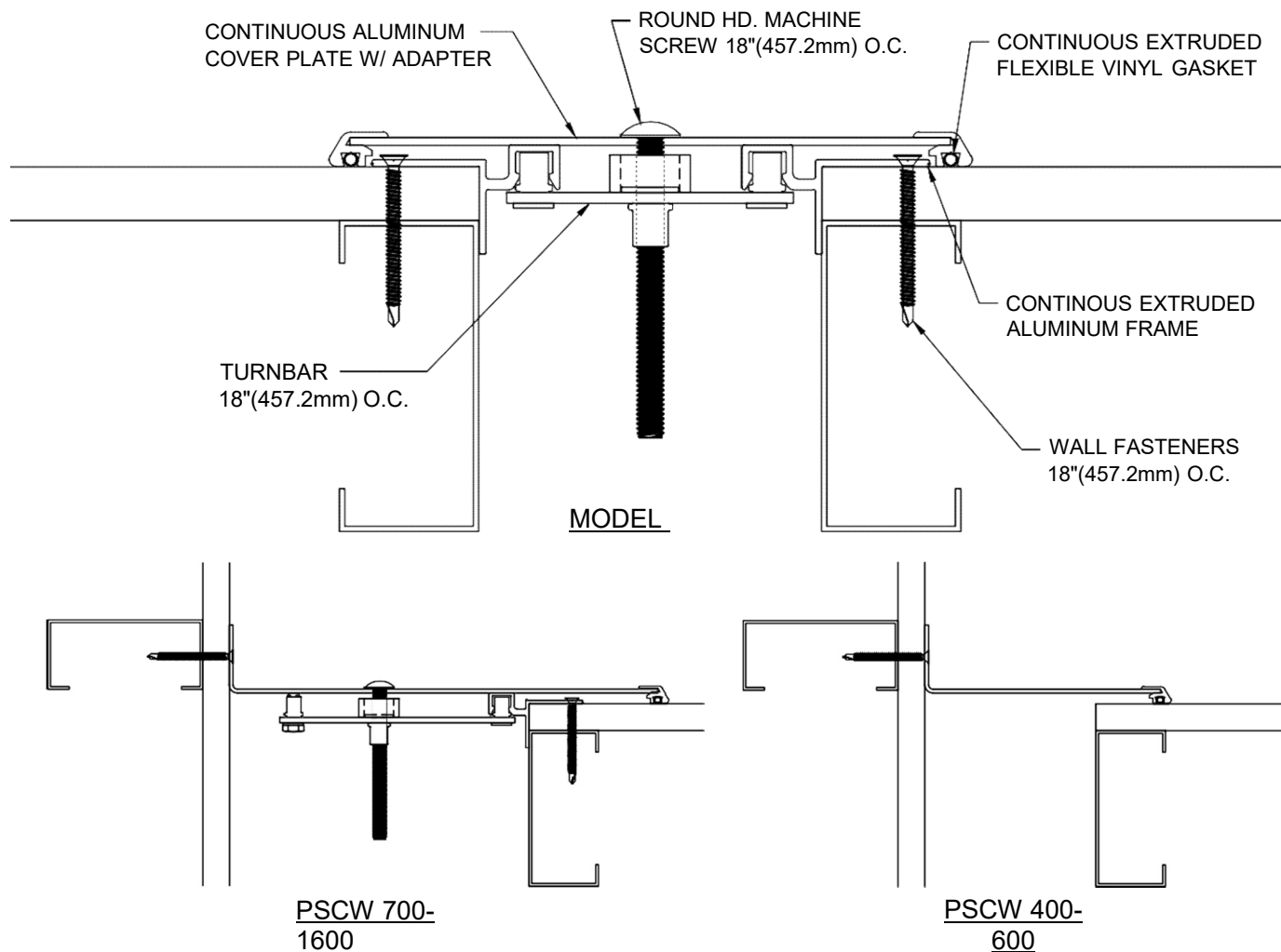

IMPORTANT INFORMATION

Prior to the commencement of installation, all materials MUST be inspected for damage. Any damage must be reported to PINNACLE SOLUTIONS, as soon as possible, so that replacement materials may be furnished without delay.

All work must be completed as per Architect's Approved "Shop Drawings", and in accordance with these Installation Instructions. When installation is complete, all materials must be protected from damage until the Architect's FINAL INSPECTION.

All materials should be arranged in the order that they are to be installed. All hardware required for each portion of the work should be placed with the appropriate materials.

Please review all Approved Shop Drawings and this document to familiarize yourself with all the details and components of this assembly.

IMPORTANT:

READ THROUGH ALL INSTRUCTIONS PRIOR TO STARTING INSTALLATION

Notes:

Before beginning installation, review the architectural drawings and approved Pinnacle Solutions Inc. shop drawings to familiarize yourself with the appropriate joint cover models and locations.

Check all of the joint cover components to confirm that the correct joint cover model and size have been received. Also, check for materials that may have been damaged during shipping. Report all incorrect and/or damaged components to PS.

Refer to the Architectural drawings and shop drawings for proper joint width and location.

Read through all the steps of these instructions prior to beginning work.

STEP 1

FRAME INSTALLATION

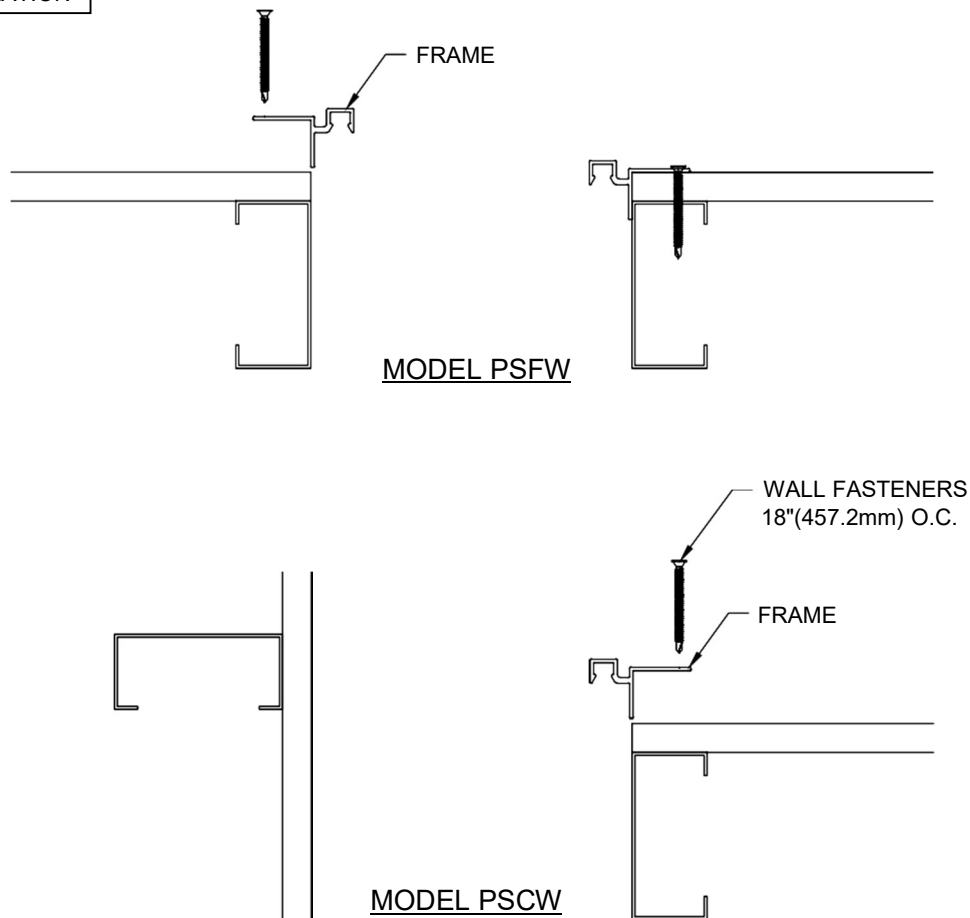

Step 1:

Note: - If a PS Fire Barrier is to be installed in the joint, please review the Fire Barrier Installation Instructions supplied, and if required install the Fire Barrier **BEFORE** installation of PS Seismic Expansion Joint Aluminum Frames.

- For Model PSCW-400 through 600, does not require Frame installation. Skip to Step 3; instructions at the bottom of the page.

- 1.1) Begin installation of Frame by placing a length of Frame on the edge of Seismic Joint and cut to length needed.
- 1.2) Using the Frame as a template, mark the locations for the PS supplied fasteners.
- 1.3) If needed, remove the Frame and drill the holes for the PS supplied fasteners.
- 1.4) Attach the Frames using the PS supplied fasteners per approved shop drawings and in accordance with the manufacturer's guidelines.
- 1.5) Repeat these installation instructions for any additional lengths of Frame and for the opposite side of the joint for Model PSFW.

STEP 2

SPACER INSTALLATION

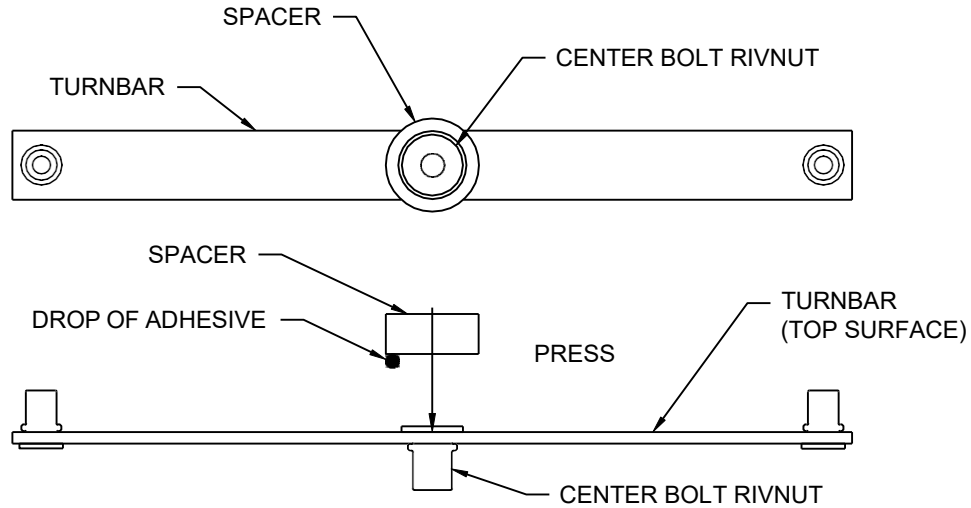

Step 2:

Note: - A Spacer must be placed between the Turnbar and the underside (or backside) of the Cover Plate. The Spacer is used to prevent excess bowing of the Turnbars when the center bolt is tightened. (Some bowing of the Turnbars is required to apply the holding force on the Cover Plate.)

- Model PSCW-400 through 600 does not require turnbar installation. Skip to Step 3; instructions at the bottom of the page.

- 2.1) Place a small drop of instant adhesive (not supplied) onto one end of a Spacer.
- 2.2) Position the end of the Spacer with the adhesive against the top surface of the Turnbar, centered over the flat head portion of the Center Bolt Rivnut (see detail above).
- 2.3) Press firmly for a few seconds until the Spacer is bonded to the Turnbar.

STEP 3

TURNBAR/COVER PLATE INSTALLATION

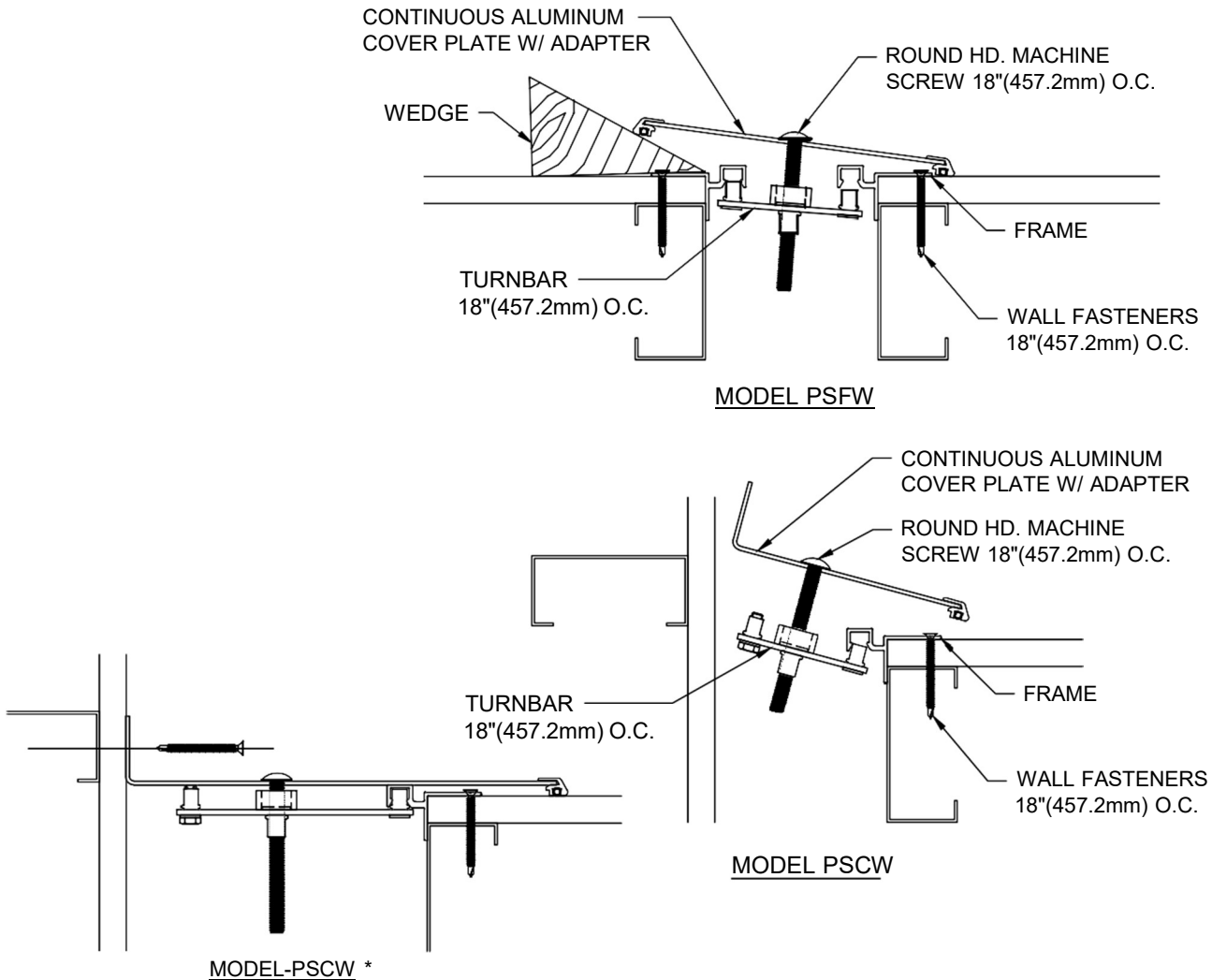

Step 3:

- 3.1) Begin installation of the Cover Plate by first cutting the Plate to length as needed.
- 3.2) Attach a Turnbar to the backside of the Cover Plate at each hole location. (Note the orientation of the Turnbar in the detail above.) Thread a machine screw only approx. 1/4" into the Turnbar for now.
- 3.3) Place the Seismic Wall Cover/Turnbar Assembly against one side of the Seismic Expansion Joint at an angle that will allow hand penetration behind the Cover Plate. With the Cover Plate in this position, reach behind the Cover Plate and locate the top pivot pin of the Turnbar into the pivot pin receivers of the Frame on each side of the joint (one side on Model PSCW).
- 3.4) Slide a wedge block beneath the Cover Plate to hold the Turnbar securely into position.
- 3.5) Repeat this procedure with the bottom Turnbar.
- 3.6) Locate each of the remaining Turnbars into position, then progressively tighten all machine screws until the Cover Plate is securely fastened onto the Frame system. (**Note: The Turnbars must be angled the same direction to allow for movement.**)

Notes:

-PSCW-400 through 600 does not require turnbar installation, only Plate installation is required.

*For Model PSCW, attach the Center Plate to the wall using the PS supplied fastener per approved shop drawing and in accordance with the manufacturer's guidelines.

STEP 4

COMPLETE INSTALLATION

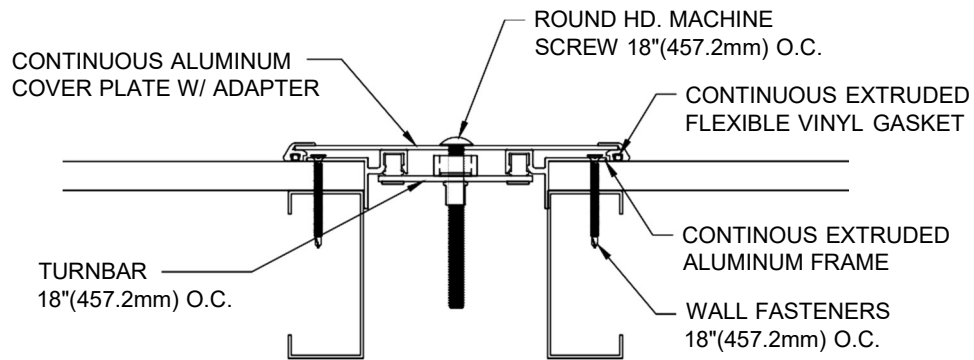

MODEL PSFW

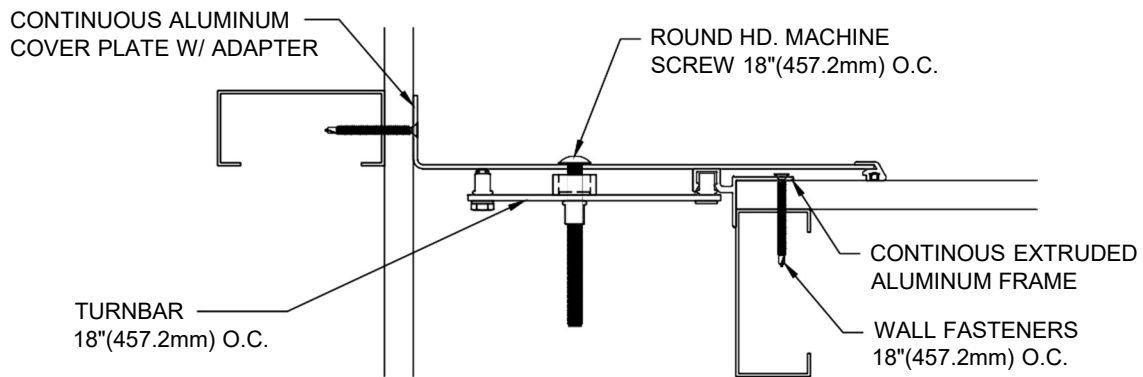

MODEL PSCW

Step 4:

- 4.1) When installation of the Joint Cover has been completed, remove all residue and foreign matter from the area and joint cover.
- 4.2) Clean the PS Joint Cover and adjoining surfaces with proper cleaner.
- 4.3) Protect the Joint Cover until the Architect's final inspection.