

MODEL PPTCP AND PPTCPW INSTALLATION INSTRUCTIONS

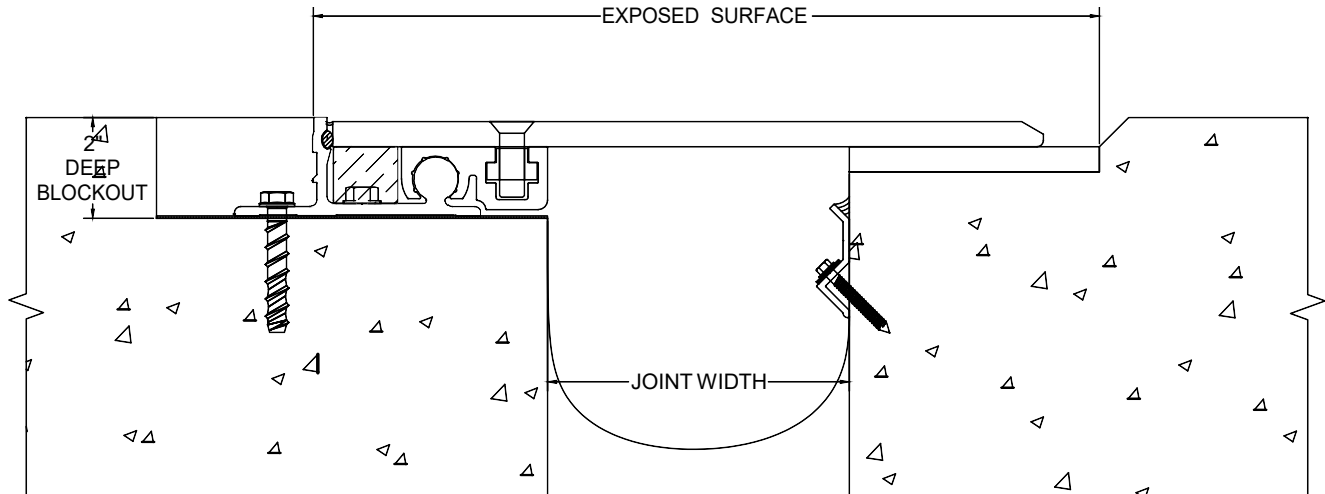

IMPORTANT INFORMATION

Prior to the commencement of installation, all materials **MUST** be inspected for damage. Any damage must be reported to PINNACLE SOLUTIONS, as soon as possible, so that replacement materials may be furnished without delay.

All work must be completed as per Architect's Approved "Shop Drawings", and in accordance with these Installation Instructions. When installation is complete, all materials must be protected from damage until the Architect's FINAL INSPECTION.

All materials should be arranged in the order that they are to be installed. All hardware required for each portion of the work should be placed with the appropriate materials.

Please review all Approved Shop Drawings and this document to familiarize yourself with all the details and components of this assembly.

IMPORTANT:

READ THROUGH ALL INSTRUCTIONS PRIOR TO STARTING INSTALLATION

GENERAL INSTALLATION NOTES:

1. Joint Width and Blockout sizes **must be** in accordance with the architectural details and PS shop drawings before installation can begin.
2. Blockouts **must be** flat and level. All repairs to the mounting surfaces **must be** done prior to the installation of the joint cover system.
3. The installer should follow all safety instructions listed in these installation documents and/or listed on the MSD sheets provided.
4. The PS shop drawings are required for use with these installation instructions. Many of the dimensions shown are variables that require the shop drawings to provide the correct number for each particular size and model.

STEP 1

PPTCP VAPOR BARRIER

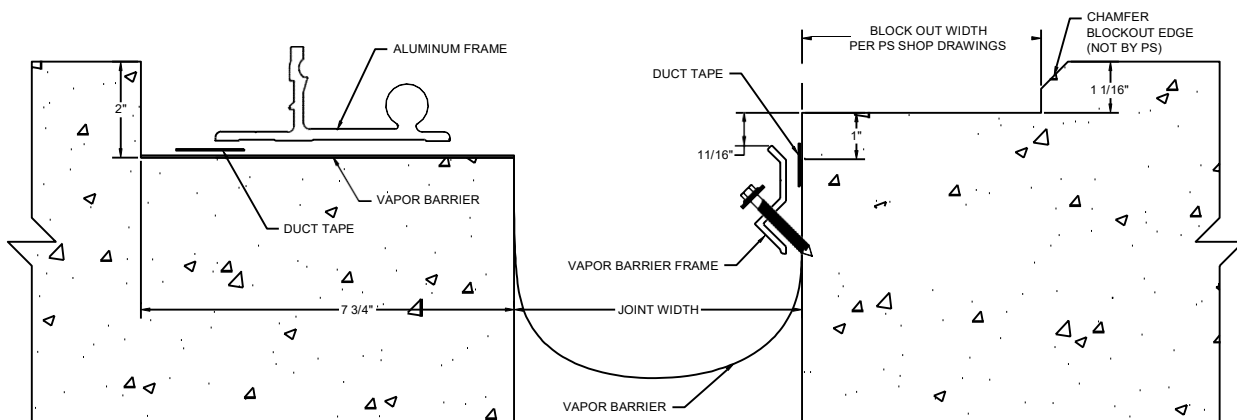

The Vapor Barrier should be installed in as long of runs as possible to reduce the number of splices. All sizes of Vapor Barrier are provided in 100' rolls.

Specialized installation instructions are provided for splicing, drain installation and end closures. See these instructions if any of these conditions are required.

Step 1:

1. At the Beveled blockout side of the joint use the Vapor Barrier Frame as a template and drill all holes necessary to fasten the Frame. Note: The top of the Vapor Barrier Frame should be about 11/16" lower than the bottom of the blockout in the joint.
2. Place the Vapor Barrier in the bottom of the blockout (Base/Rotational Frame Side) back 6 1/4" from the joint edge and hold in place with duct tape (see detail above).
3. Place the other edge of the Vapor Barrier against the opposite blockout, leaving it 1" down from the top of the blockout. Duct tape to fasten Vapor Barrier in place. Press the Vapor Barrier material into the joint to create a drape. It may be necessary to place a small block of wood in the drape to hold it down into the joint until the installation of the frame is complete.
4. Place the Vapor Barrier Frame back into the joint, align with the mounting holes and fasten into place using the PS supplied hardware shown on the shop drawings.
5. Apply PS supplied Sealant along the top edge of the Vapor Barrier Frame.

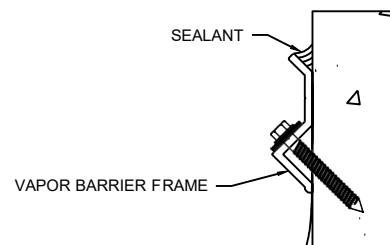

The PTC Base Frame and the PTC Rotational Frame are to be assembled as a unit prior to installation. The ends of the frames should be aligned and abut the next frame section. This enables each 12' base/rotational frame assembly to operate individually during vertical displacement.

The frames should be installed continuously for the entire length of the run. If lateral shear movement is specified the cover plate will be installed to accommodate this type of movement.

STEP 2

PPTCP BASE AND ROTATIONAL

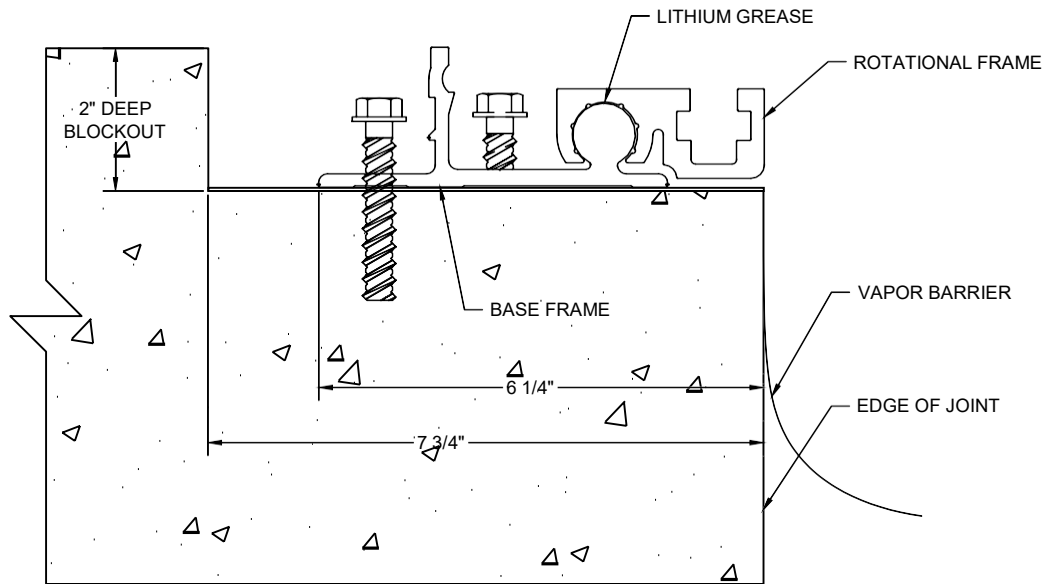

Step 2:

1. Place the Base Frame in the 2" deep blockout, locate the back edge of the Base Frame 6 1/4" back from the joint edge. While holding the Base Frame in position, drill through the Frame at each pre-drilled anchor hole using the proper drill bit for the PS supplied fasteners.
2. At the outside edge of the Frame and vapor barrier mark a couple of reference lines across the frame, vapor barrier and the blockout to assist in properly repositioning the Frame and vapor barrier.
3. Remove the Base Frame and clean/vacuum away the concrete debris and dust. Lift the vapor barrier and clean/vacuum away all concrete debris and dust at each fastener hole. *Note it is important to remove all debris to assure that the frame sits flat and solid to the blockout surface and does not rock. Reposition the vapor barrier and align with the reference marks.
4. Before installing the Base Frame, apply a liberal amount of lithium grease to the mating surfaces of the Base Frame and Rotational Frame. Smear to spread evenly, the entire surface should be covered. Assemble the Base Frame together aligning the female portion of the Rotational Frame with the male portion of the Base Frame. Aligning the end of the frames.
5. Reposition the Base Frame/Rotational Frame into the blockout and align the frame with the reference marks and check that the fastener holes align with the holes in the vapor barrier.
6. At each anchor hole in the Base Frame, begin to install one of the PS supplied fasteners into each hole. Drive the fasteners in approx. 1/2 of the fastener length according to the fastener instructions. *Note do not tighten the fasteners until all fasteners have been started to allow for small adjustments. Once all of the fasteners have been started, return and tighten all of the fasteners.

STEP 3

PPTCP EPDM PAD INSTALLATION

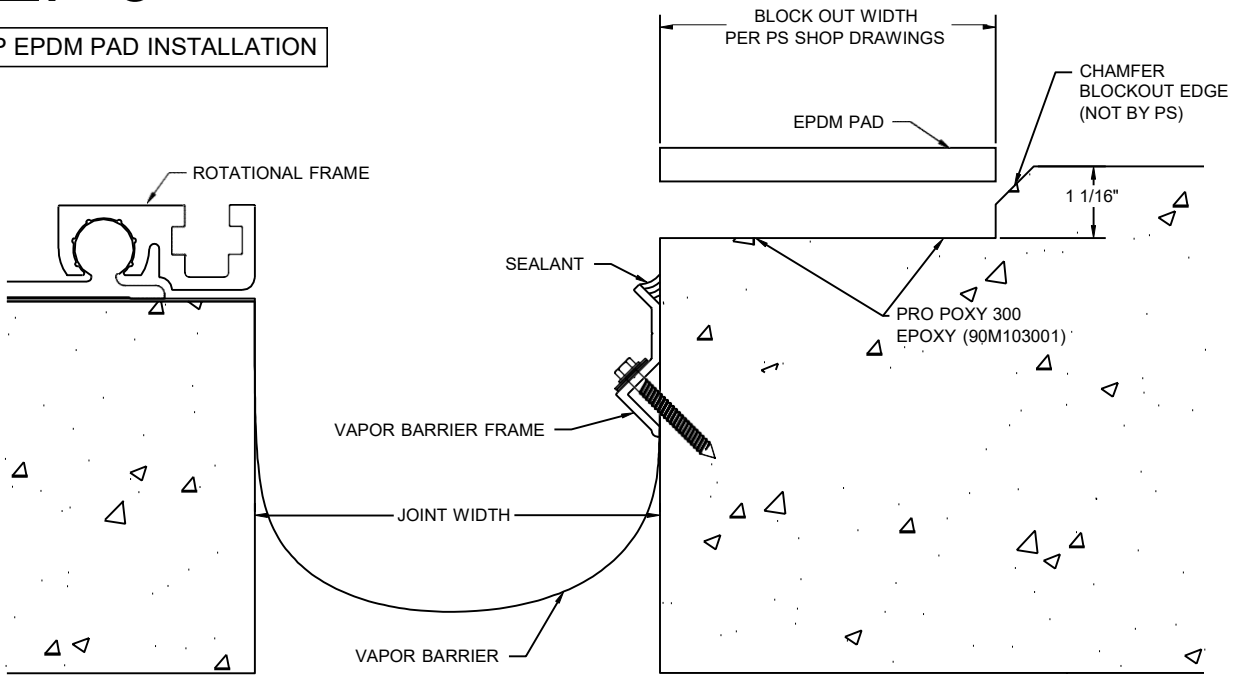

***IMPORTANT NOTE:** Do not use Epoxy or install EPDM Pad if either the substrate temperature or air temperature will drop below 40°F [5°C] during the installation or cure time of 8 hours.

Step 3:

1. Check to ensure that the concrete is free from loose dirt, debris and oils. It is critical that the concrete mounting surface area adjacent to the joint is clean to allow the Epoxy to achieve the proper bond.
2. Mix the PS supplied, 2 component Epoxy. Measure equal amounts of Part A and Part B by volume. Pour both Part A and Part B into a container and mix thoroughly for three minutes until a uniform gray color is achieved. Do not mix in direct sunlight as this will decrease the work life of the Epoxy. Only mix the amount of Epoxy that can be used within its gel time (see chart for gel time based on temperature).
3. Apply the Epoxy by loading it into a bulk gun and ejecting it onto EPDM blockout surface. Spread the Epoxy with a trowel until it is approximately 1/16" - 1/8" thick. The Epoxy must be applied quickly to allow time for the seal to be installed before it begins to gel. Once the Epoxy has begun to gel or get hot, a proper bond will not be achieved.
4. Position the EPDM Pad in the blockout, aligning with the joint edge. Ensure the EPDM Pad is in the correct position along the length of the joint. Repeat this installation for additional lengths of EPDM Pads.
5. Place boards on the entire length of EPDM Pad, placing sand bags, or something of similar weight, every couple feet on top the boards. This will force the EPDM Pad to set into the Epoxy during the cure cycle. **Note:** This is especially important at splice locations, be sure the ends of the EPDM Pad are flat and lined up. Allow the weights and boards to remain on the seal for approximately 8 hours.

APPROXIMATE WORK LIFE OF EPOXY	
TEMPERATURE	WORK LIFE
50°F [10°C]	35 MINUTES
70°F [21.11°C]	25 MINUTES
85°F [29.44°C]	20 MINUTES

STEP 4

PPTCP COVER PLATE INSTALLATION

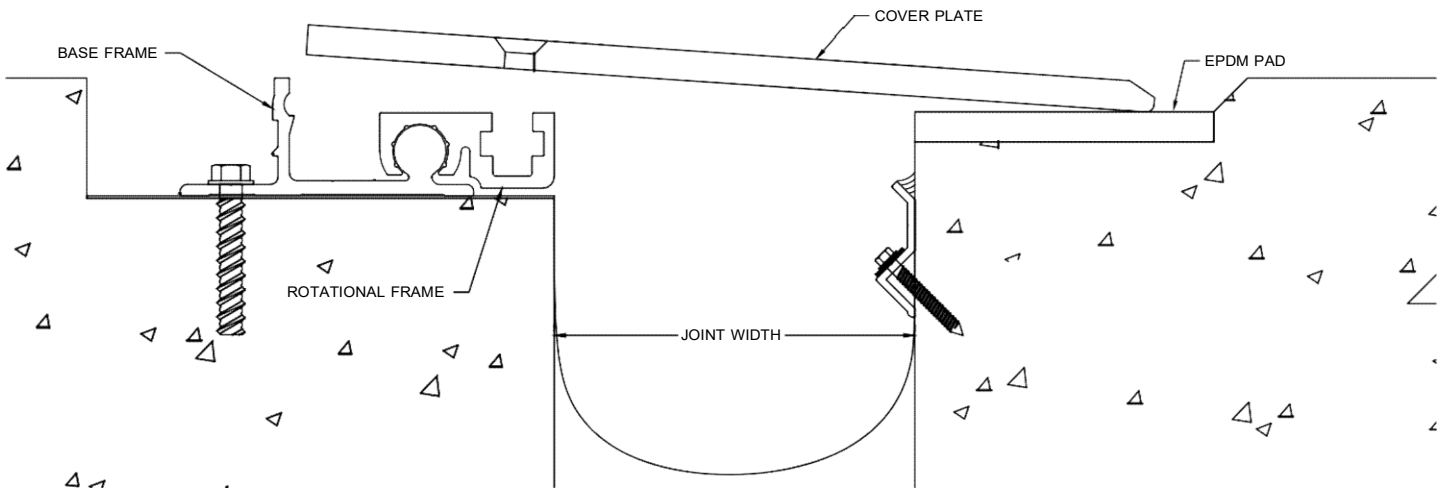

Step 4:

1. Beginning at the same end of the run where installation of the frame began, place a length of Cover Plate on top of the frame and EPDM Pad with the edge with the countersunk holes resting on the Rotational Frame and the beveled end resting on the EPDM Pad. Align the ends of the Cover Plate with the end of the first length of frame.
2. Looking into the countersunk holes, slide the plate towards or away from the joint until the top surface of the Rotational frame can be seen. Using the countersunk holes to place a mark on the surface of the Rotational Frame. Slide the Cover Plate over onto the EPDM Pad.
3. At the Rotational Frame, slide T-Nuts and align the hole of the T-Nut with each mark on the Rotational Frame.
4. At the space between the Rotational Frame and the leg of the Base Frame, place a $1 \frac{1}{4}$ " x $1 \frac{1}{4}$ " x 2" long EPDM Spring into the space and centered with each mark on the Rotational Frame. Note: The 2" length is to be visible from the top. If there is an anchor bolt at this location, simply place the EPDM Spring beside the anchor, closest to the mark. The EPDM Springs, when placed under compression, will apply a downward force at the beveled end of the Cover Plate to reduce noise and to facilitate vertical movement.

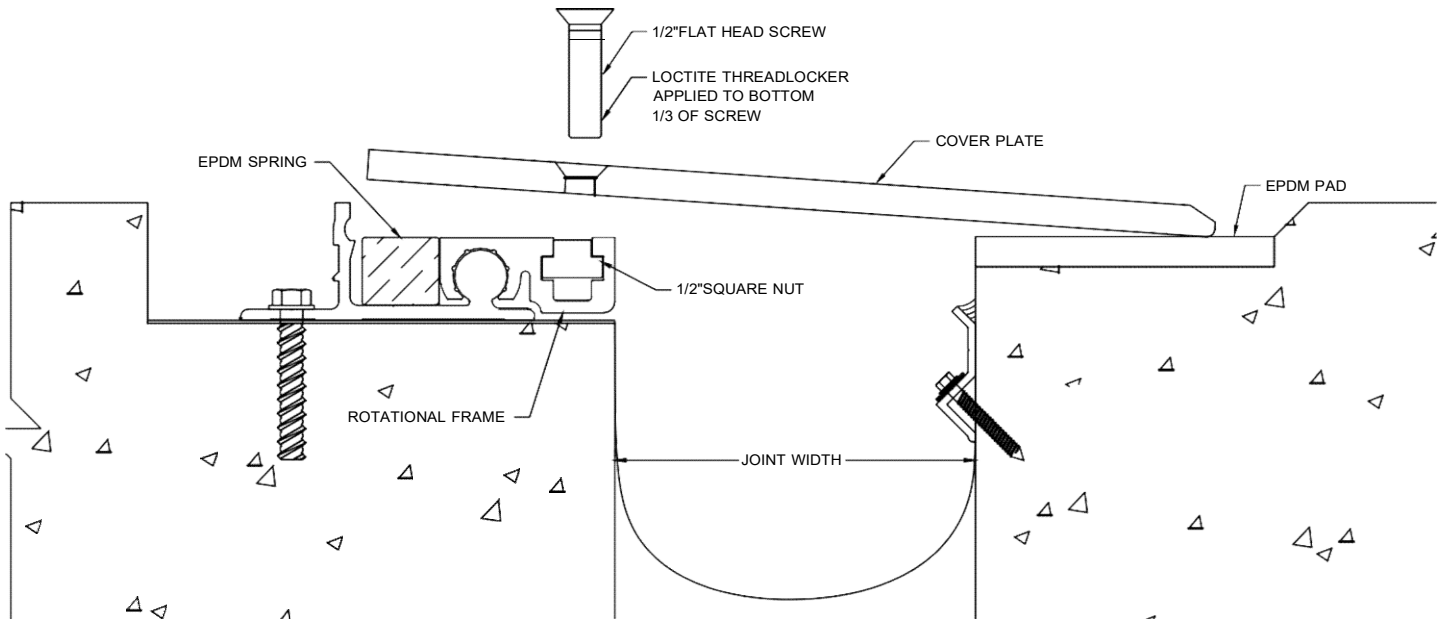

CON'T. STEP 4

PPTCP COVER PLATE INSTALLATION

Step 4:

5. Reposition the Cover Plate over the joint and align the holes in the cover with the T-Nuts and with the ends of the plate aligned with the end of the frame. Use a screwdriver or similar to reach through the holes to adjust the T-Nuts to center them with the holes.
6. Take one of the PS supplied 1/2-13 x 1 1/2" Hex Socket Head, Flat Head Bolts and apply a small amount of PS supplied Loctite Thread locker to the threads near the tip of the bolt.
7. Begin at one end of the Plate and insert the Flat Head Bolt through the countersunk hole, and by hand, begin to thread it into the T-Nut, care should be taken not to cross thread the nut. Repeat the threadlocker application and hand threading of the bolts at all the Cover Plate attachment holes.
8. Once all of the fasteners have been started, work back across the plate and tighten each screw by hand. Once hand tight, using a Torque Wrench with a $\frac{5}{16}$ " Hex Bit Socket tighten each bolt to 60 ft. lbs.. (The use of an impact wrench or power drivers is not recommended.) Note: Once all of the bolts have been tightened, the top edge of the cover plate should be flush with the top of the Base Frame or slightly below. If the top edge of the plate is above the frame, increase torque to 70 ft. lbs. and tighten the bolts in this area. If the plate edge is still slightly above, leave it as is.

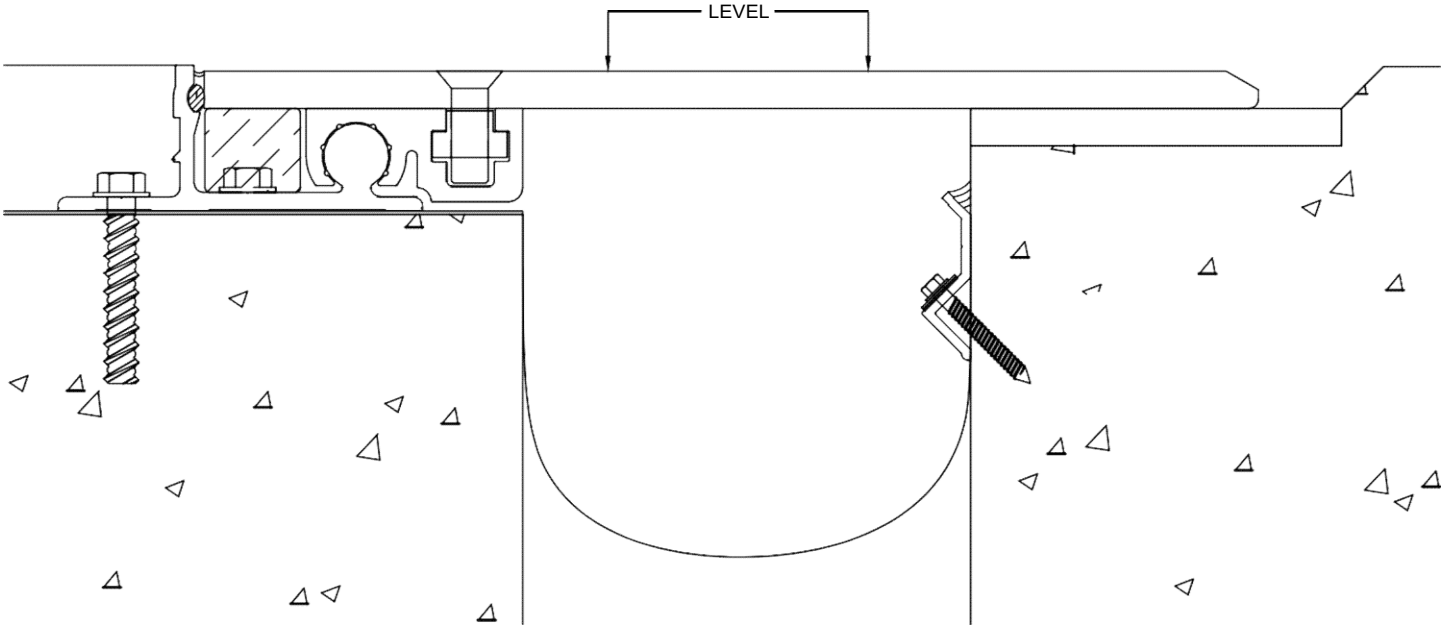

STEP 5

END PLATE INSTALLATION

The PPTCP and PPTCPW End Plates are installed where lateral shear is a requirement. The End Plates will detach during a seismic event and allow the PPTCP cover system to perform lateral movement without damaging the Cover Plate or any surrounding material. After the End Plate has been detached, reattach with silicone adhesive according to these instructions.

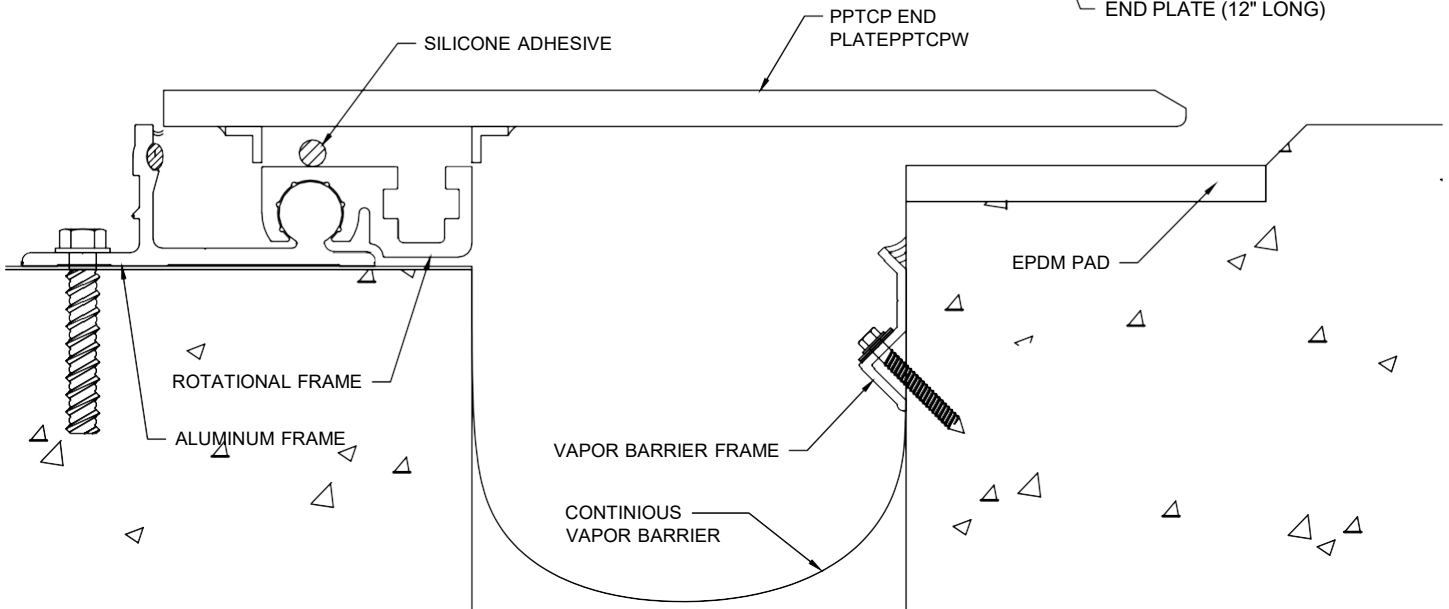
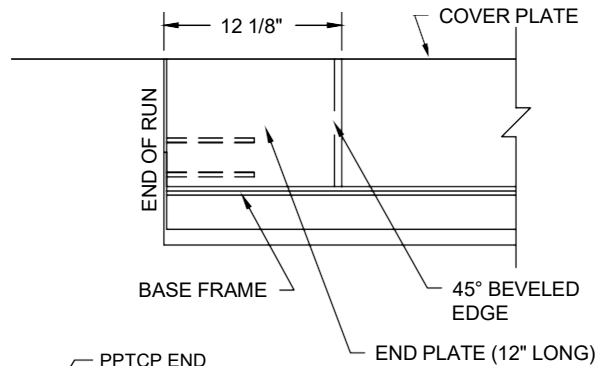

Note: End Plates are required at each end of a run of PPTCP/PTPCW cover. When lateral movement is required, prior to beginning installation of the Cover Plates position PS supplied End Plate at end of run next to joint. No EPDM Spring should be placed at the End Plate location. Restrict all pedestrian and vehicular traffic from crossing the End Plate until adhesive has cured.

Step 5:

1. Apply a 1/2" bead of Silicone Adhesive to the top of the Rotational Frame at the beginning of the run.
2. Place the PPTCP End Plate on top of the Rotational Frame with the 45 degree beveled edge down and towards the standard run of PPTCP Cover Plate. Only a hairline gap should be left between the End Plate and the end of the standard Cover Plate.

STEP 6

ELASTOMERIC CONCRETE INSTALLATION

NOTE:

PS Elastomeric Concrete protects the exposed concrete edges at the back of the blockouts and provides a water tight seal between the frames and the concrete. Care should be taken to protect the surrounding surfaces from stains caused by the Elastomeric Concrete.

1. All surfaces of the joint cover system must be taped or covered to prevent contact with the elastomeric concrete. A strip of duct tape must be placed adjacent to each blockout to be filled with Elastomeric Concrete.
2. Mix according to the instructions provided PS Elastomeric Concrete with the components of the system. The chemical compounds in the Elastomeric Concrete are moisture and temperature sensitive. Be sure to read all of the instructions carefully. Elastomeric Concrete will fill the remaining voids in the blockout and create a smooth driving surface.
3. Fill the voids between the Base Frame and Slide Frame and the edges of the blockout, then smooth with a trowel.

4. Allow the Elastomeric Concrete to harden before allowing traffic on the cover system.

STEP 7

BACKER ROD & CAULK INSTALLATION

Backer Rod and Caulking are installed between the Cover Plate and the exposed edge of the Base Frame to prevent water and debris from collecting in the Compression Spring recess. The exposed metal surfaces on both edges of the joint to be caulked should be protected by duct tape prior to beginning the installation.

Step 7:

1. Place the 3/8" Backer Rod in the gap between the Cover Plate and the exposed edge of the Base Frame.
2. Push the Backer Rod into the gap with a screwdriver or similar tool until it snaps or expands into the receiver in the Base Frame.
3. Once the Backer Rod is in place, apply the caulk provided to the top of the Backer Rod sealing the joint.
4. Smooth the caulking with a trowel or similar tool.

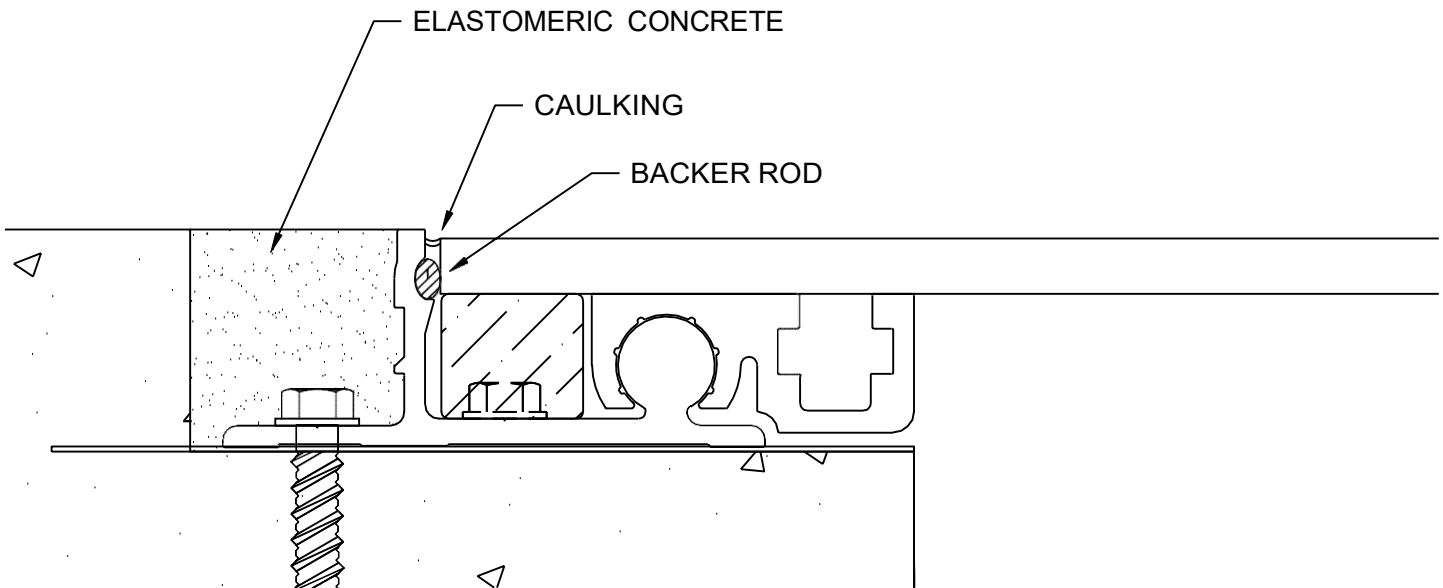

This completes the linear installation of the PPTCP Model. The following instructions are for the installation of Corner conditions.

STEP 8

CORNER CONDITION INSTALLATION

These instructions are for the installation of Inside, Outside, and Odd Angle Corners. The end of each frame and cover plate have to be miter cut to fit the corner condition and allow for at least a 1/4" gap between the Cover Plates and Rotational Frames.

Step 8:

1. Miter cut the end of each Base Frame and install as normal leaving only a hairline space between the frame sections.
2. Miter cut the Rotational Frames and install as normal leaving at least a 1/4" gap between the frame sections.
3. For a PPTCP installation where lateral shear is not a requirement, the ends of the Cover Plates should be miter cut, aligned with the ends of the Rotational Frames, allowing for the 1/4" gap, and attached as normal.
4. For a PPTCP installation where lateral shear is a requirement, an End Plate must be installed on either side of the corner miter. The End Plates must be miter cut, aligned with the end of the Rotational Frame, allowing for the 1/4" gap, and attached with Silicone Adhesive as normal.

Note:

The 1/4" gap between the Cover or End Plates in the lateral shear installation can be filled with caulking if desired or required by the project.

STEP 9

PPTCPW VAPOR BARRIER

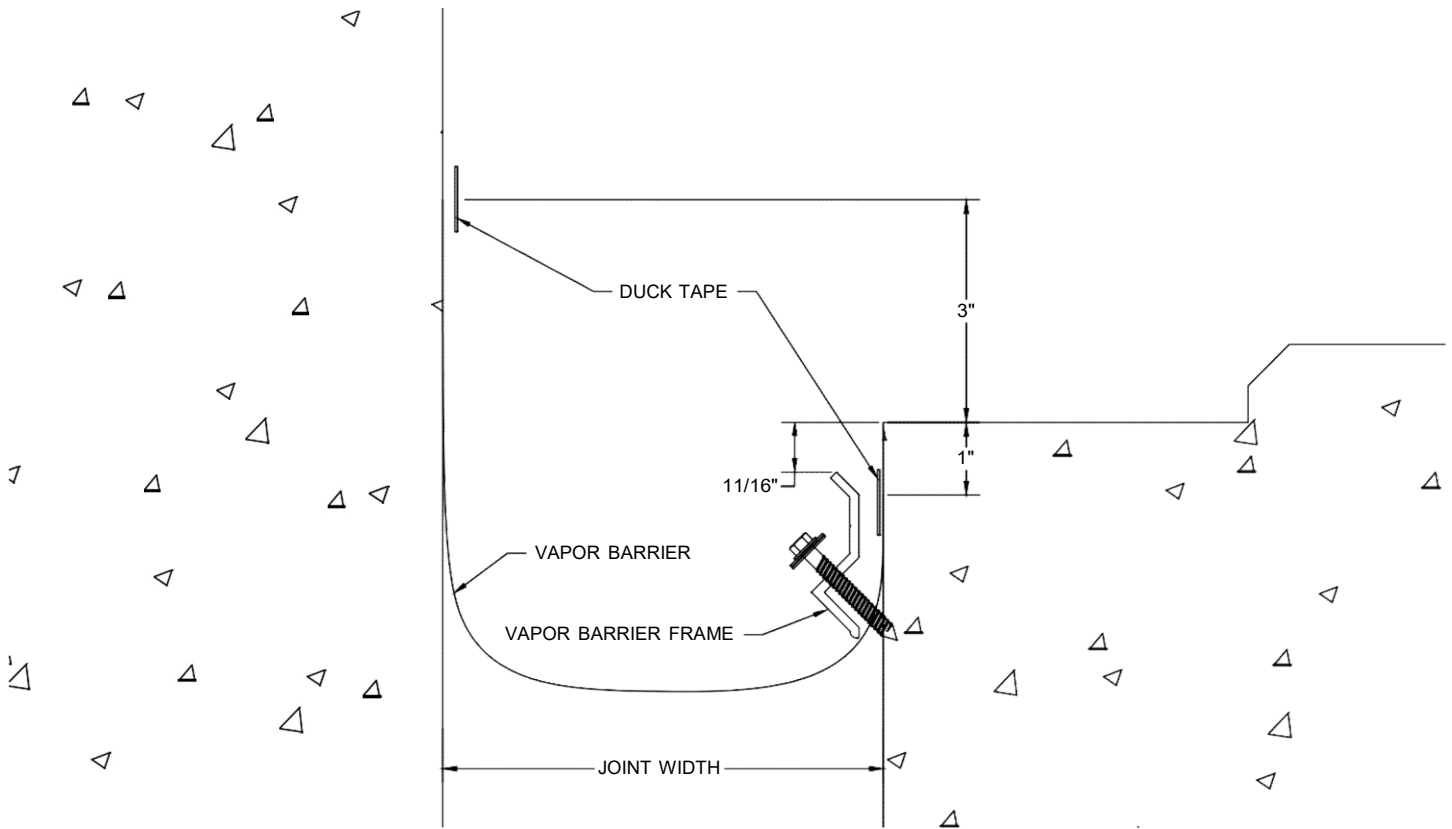

Step 9:

1. At the Beveled blockout side of the joint use the Vapor Barrier Frame as a template and drill all holes necessary to fasten the frame. Note: The top of the Vapor Barrier Frame should be about 11/16" lower than the bottom of the blockout in the joint. Place the Vapor Barrier 1" down from the top of the blockout and hold in place with duct tape.
2. Attach the other end of the Vapor Barrier to the wall 3" above the base of the blockout and hold in place with duct tape. Press the water stop material into the joint to create a drape. It may be necessary to place a small block of wood or a tool in the drape to hold it down into the joint until the installation of the frame and angle is complete.
3. Place the Vapor Barrier Frame back into the joint, align with the mounting holes and fasten into place using the PS supplied hardware.
4. Apply PS supplied sealant along the top edge of the Vapor Barrier Frame.

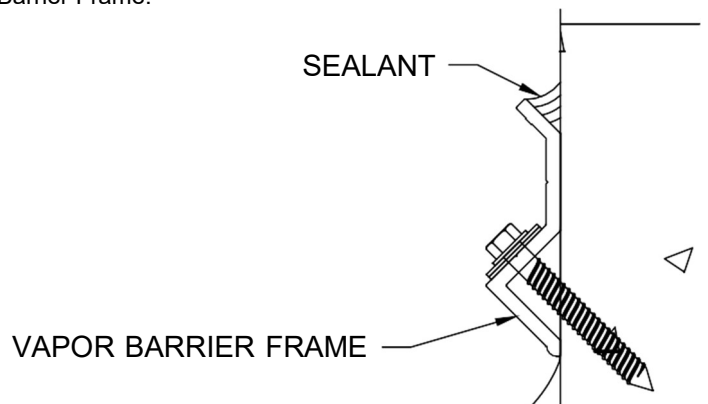

STEP 10

PTCW COVER PLATE INSTALLATION

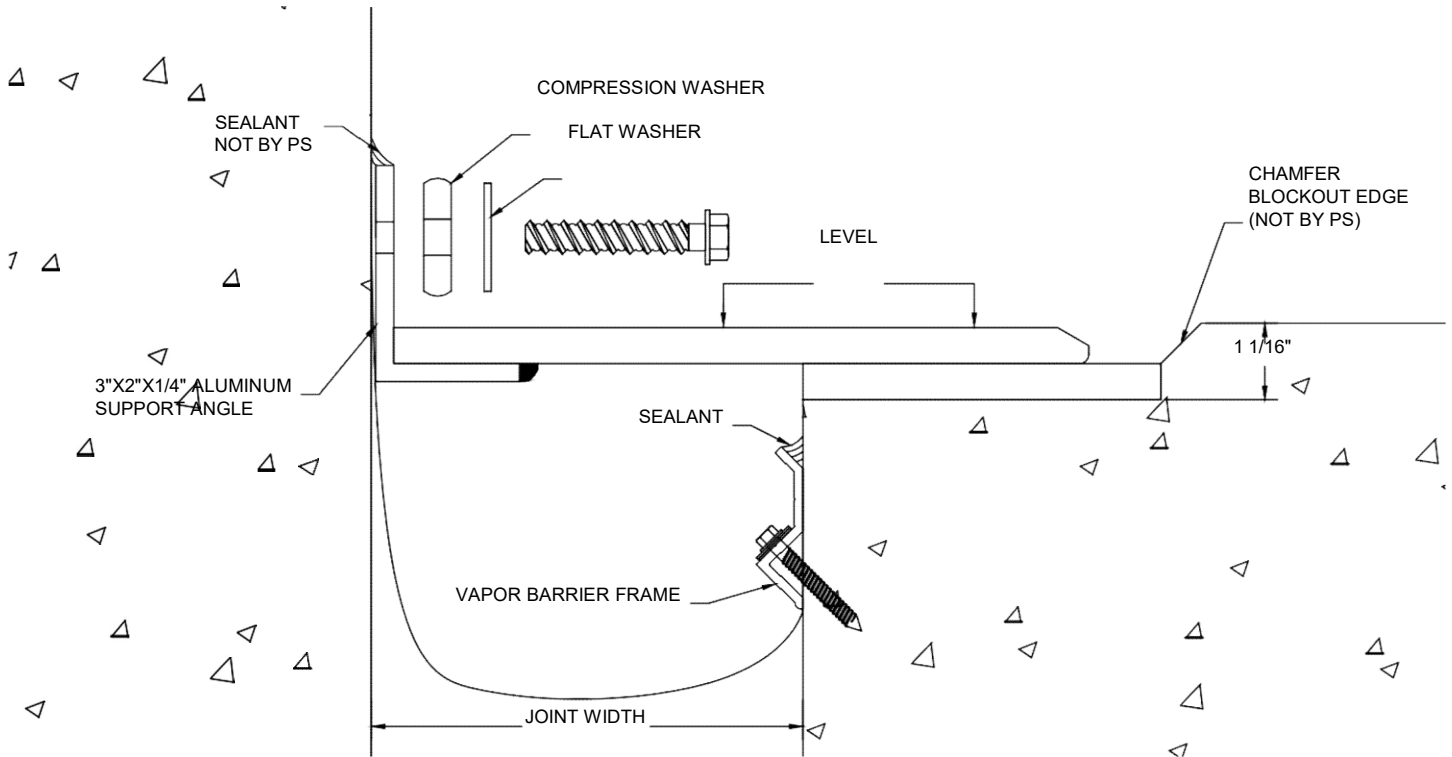

Step 10:

1. See PPTCP EPDM Pad installation instructions on page 4 for procedures on installing the EPDM Pad to the blockout.
2. Position the PTCW Cover Plate against the wall or column with the top edge aligned with the top edge of the vapor barrier. The beveled edge is to rest on the EPDM pad. While holding the wall frame in position mark all fastener holes locations. Be sure the Cover Plate is level. Remove the Cover Plate and place several reference lines along the outside edge of the vapor barrier and wall to assist in properly repositioning the frame and vapor barrier.
3. Drill the wall at each fastener hole for the PS supplied fasteners. Clean dust and debris out of the vapor barrier and from behind the vapor barrier. Reposition the vapor barrier and align with the reference marks.
4. Reposition the Wall Cover Plate and align fastener holes with the holes in the vapor barrier. Install the Rotational Compression Washer and Flat Washer onto each fastener and install the fasteners.
5. Caulk the top of the Cover Plate.