

MODEL PPDA/PPDS 100-400 & PPDAW/PPDSW 100-400 INSTALLATION INSTRUCTIONS

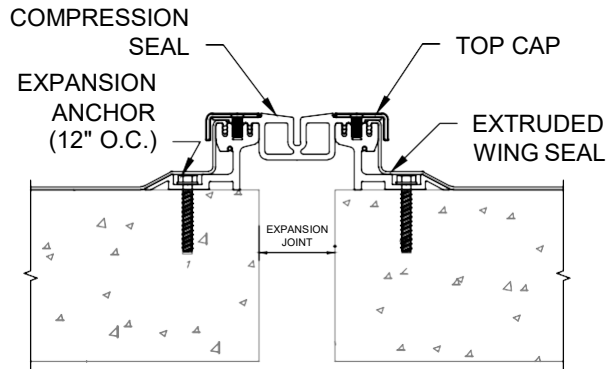

MODELS PPDA/PPDS

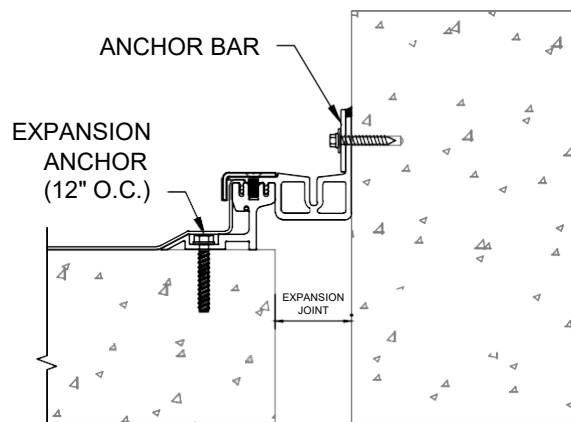

MODELS PPDAW/PPDSW

IMPORTANT INFORMATION

Prior to the commencement of installation, all materials **MUST** be inspected for damage. Any damage must be reported to PINNACLE SOLUTIONS, as soon as possible, so that replacement materials may be furnished without delay.

All work must be completed as per Architect's Approved "Shop Drawings", and in accordance with these Installation Instructions. When installation is complete, all materials must be protected from damage until the Architect's FINAL INSPECTION.

All materials should be arranged in the order that they are to be installed. All hardware required for each portion of the work should be placed with the appropriate materials.

Please review all Approved Shop Drawings and this document to familiarize yourself with all the details and components of this assembly.

IMPORTANT:

READ THROUGH ALL INSTRUCTIONS PRIOR TO STARTING INSTALLATION

MODELS & APPLICATION

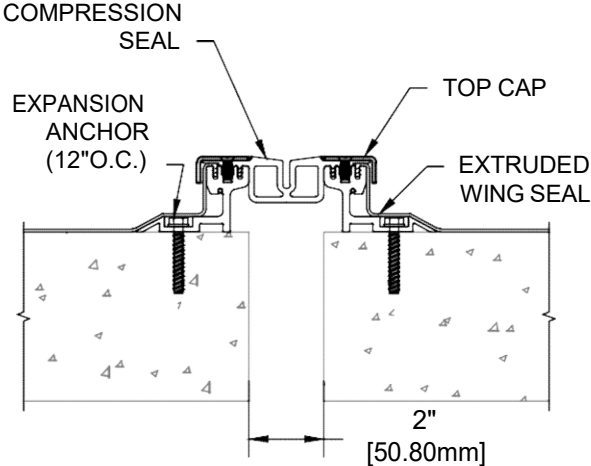

MODELS PPDA/PPDS -200

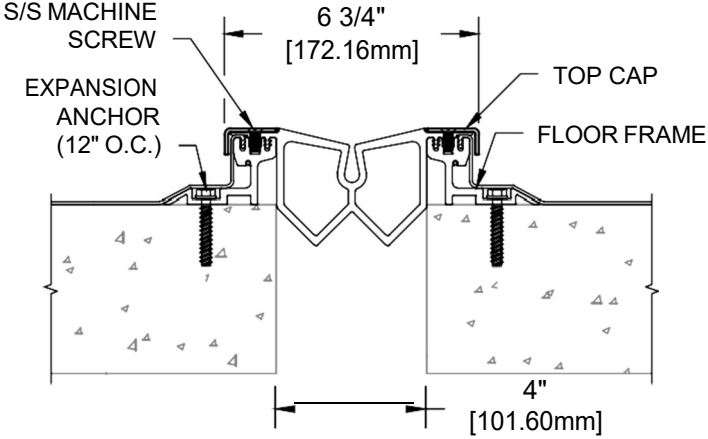

MODELS PPDA/PPDS -400

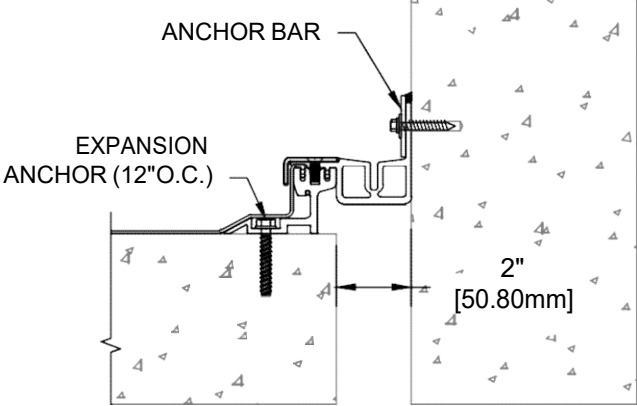

MODELS PPDAW/PPDSW -200

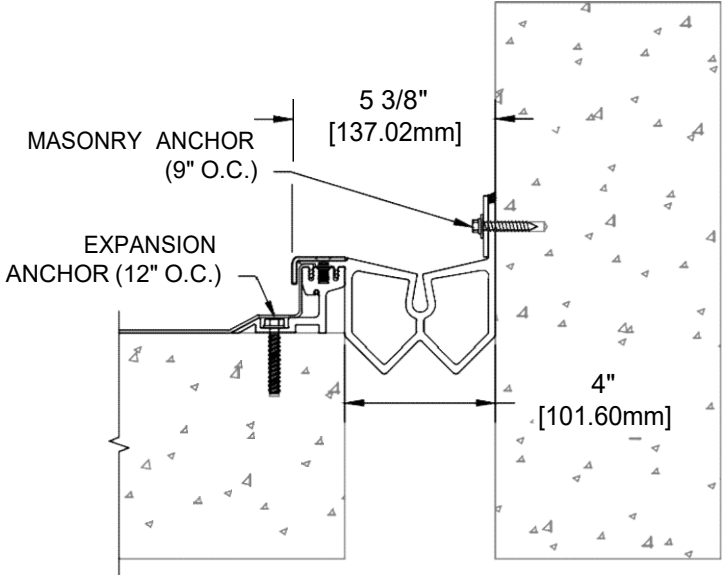

MODELS PPDAW/PPDSW -400

MODEL PPDA/PPDS 100/300 OFFSET CONDITIONS

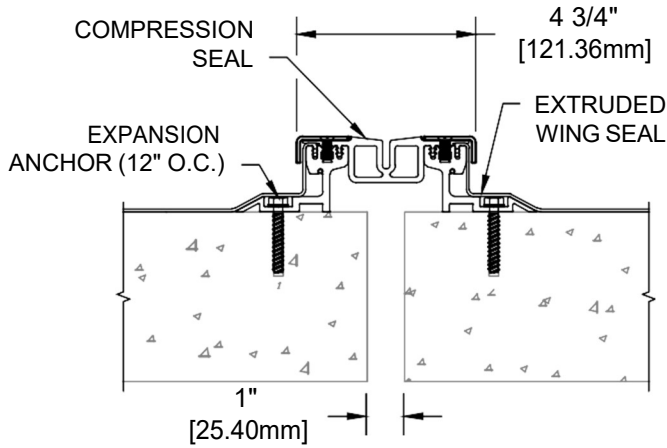

MODELS PPDA/PPDS - 100

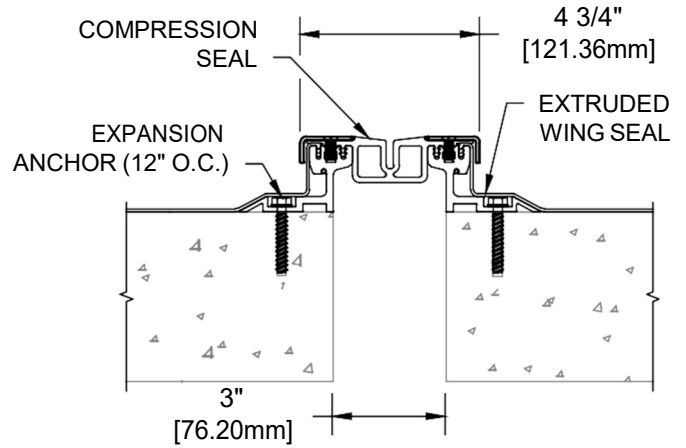

MODELS PPDA/PPDS - 300

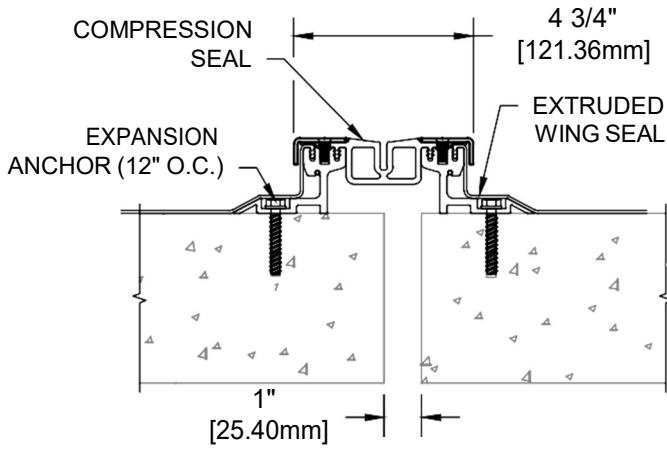

MODELS PPDA/PPDS - 100 AT
OFFSET

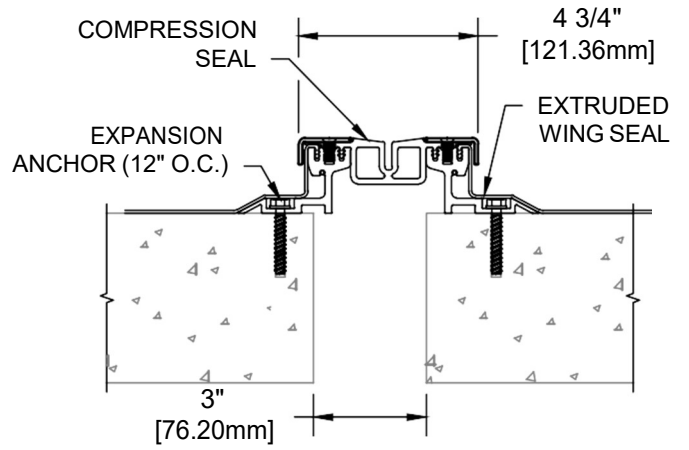

MODELS PPDA/PPDS - 300 AT OFFSET

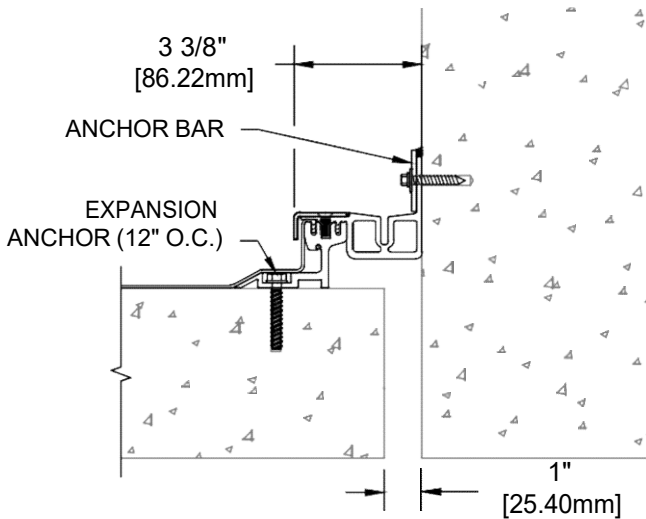

MODELS PPDAW/PPDSW - 100

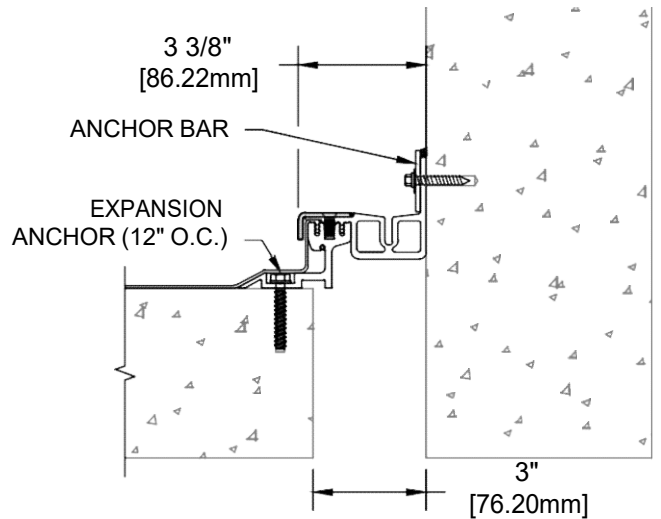

MODELS PPDAW/PPDSW - 300

Notes

Before beginning installation, review the architectural drawings and approved PINNACLE SOLUTIONS Inc. shop drawings to familiarize yourself with the joint cover models and locations.

Check all of the joint cover components to confirm that the correct joint cover model and size have been received. Also, check for materials that may have been damaged during shipping. Report all incorrect and/or damaged components to PS.

Read through all the steps of these instructions prior to beginning work.

STEP 1

SURFACE PREPARATION

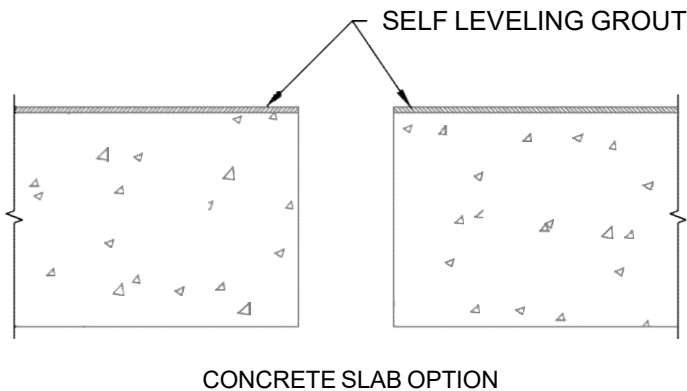

Note: The PPDA/PPDS models can be adapted to many field conditions. Depending on the field condition either a concrete slab or a blockout will need to be prepared first.

- 1.1) It is recommended that the slab or blockout be formed a minimum of $\frac{1}{8}$ " deeper to allow the top surfaces to be leveled before installation of the joint cover. (Note: Elevation may be adjusted as needed to accommodate surface finish when required.)
- 1.2) Apply a self leveling grout to the base of the concrete surface to provide a continuous, solid, flat and level base for the joint cover. (Note: The blockouts must be level across the width of the joint.)

JOINT SIZE	BLOCKOUT WIDTH ("Y")
1" [25.4mm]	4" [101.6mm]
2" [50.8mm]	3 1/2" [88.9mm]
3" [76.2mm]	3" [76.2mm]
4" [101.6mm]	3 1/2" [88.9mm]

FRAME DEPTH	BLOCKOUT DEPTH ("X")
2" [50.8mm]	2" [50.8mm]
3" [76.2mm]	3" [76.2mm]
4" [101.6mm]	4" [101.6mm]
5" [127.0mm]	5" [127.0mm]

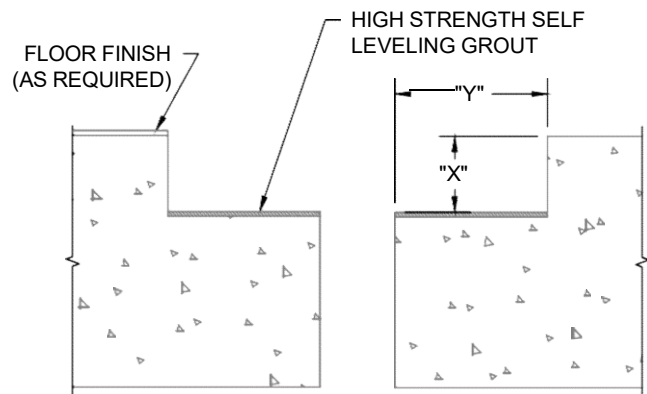

BLOCKOUT OPTION

STEP 1 CON'T

SURFACE PREPARATION - BLOCKOUT OFFSET CONDITION

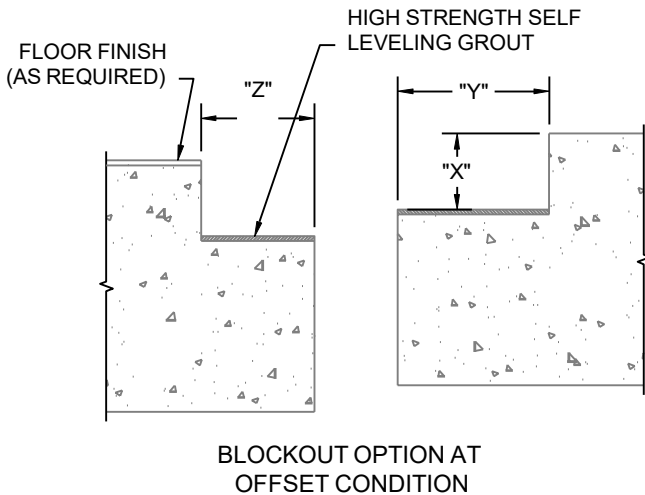

Note: The PPDA/PPDS offset conditions for 1" & 3" models can be adapted to many field conditions. Depending on the field condition either a concrete slab or a blockout will need to be prepared first.

- 1.1) It is recommended that the blockout be formed a minimum of $\frac{1}{8}$ " deeper to allow the top surfaces to be leveled before installation of the joint cover. (Note: Elevation may be adjusted as needed to accommodate surface finish when required.)
- 1.2) Apply a self leveling grout to the base of the concrete surface to provide a continuous, solid, flat and level base for the joint cover. (Note: The blockouts must be level across the width of the joint.)

FRAME DEPTH	BLOCKOUT DEPTH ("X")
2" [50.8mm]	2" [50.8mm]
3" [76.2mm]	3" [76.2mm]
4" [101.6mm]	4" [101.6mm]
5" [127.0mm]	5" [127.0mm]

JOINT SIZE	BLOCKOUT WIDTH ("Y")	BLOCKOUT WIDTH ("Z")
1" [25.4mm]	4 1/2" [114.3mm]	3 1/2" [76.2mm]
3" [76.2mm]	3 1/2" [88.9mm]	2 1/2" [63.5mm]

Note: As an alternate surface preparation/Floor Frame installation method, an epoxy mortar bed can be spread on the surfaces that are going to be receiving the Floor Frame. The epoxy mortar bed should be approximately $\frac{3}{8}$ " [9.53mm] thick x 5" [127.00mm] wide on both sides of the joint. The epoxy-mortar can be used to fill in any irregularities on the concrete slab or blockout.

- The Floor Frame should be set in the epoxy mortar bed before it is cured.
- The Floor Frame can be tapped down until the top surface is at the correct elevation.
- Continue this procedure for the entire run of joint cover. (Note: If needed the frames can be slightly lifted to insert the alignment pins.
- Allow the epoxy mortar to cure per the manufacture's instruction.
- Drill all holes for the PS Supplied Expansion Anchors to the specifications provided by the expansion anchor's manufacturer.
- Fasten the Floor Frame to the substrate using the PS Supplied Expansion Anchors

STEP 2

FLOOR FRAME INSTALLATION

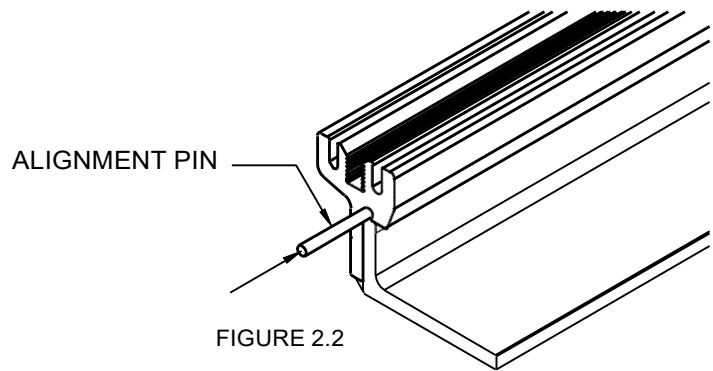

FIGURE 2.2

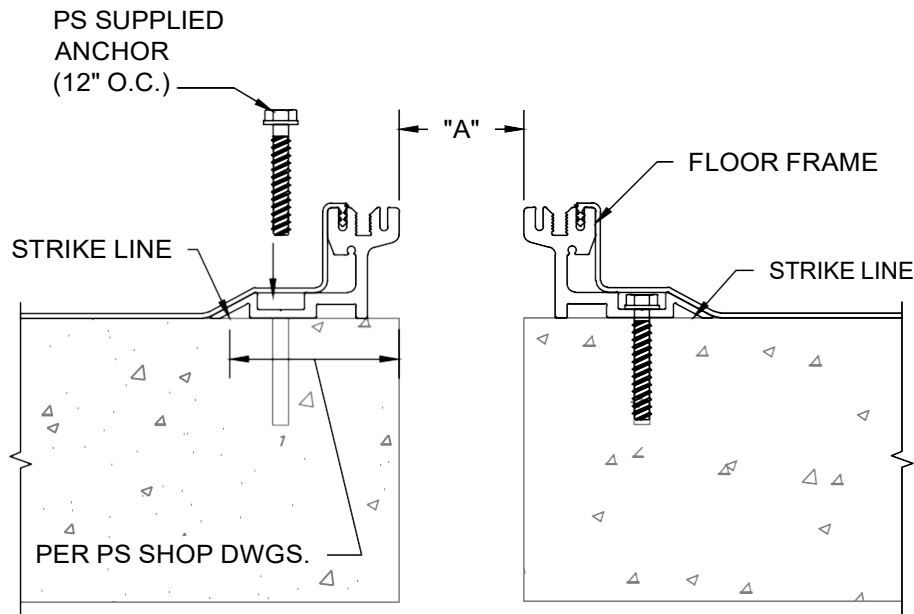

FIGURE 2.1

Model	DIM. "A"
PPDA/S-100	2" [50.8mm]
PPDA/S-200	2" [50.8mm]
PPDA/S-300	2" [50.8mm]

Note: If a PS Fire Barrier is to be installed in the joint, please review the Fire Barrier Installation Instructions supplied, and if required install the Fire Barrier **BEFORE** installation of PS Seismic Expansion Joint Floor Frame(s).

If factory fabricated miters have been provided installation should begin by installing the miters first and then installing the straight lengths working out from the miters. (see Installation Instructions 12EB)

- 2.1) Locate the back edge of the Floor Frame by measuring back per PS shop drawing from the edge of expansion joint and striking a line the length of the run. (See Figure 2.1)
- 2.2) Set the Floor Frame so that the back edge of the Frame lines up with the line.
- 2.3) Using the Floor Frame as a template mark and drill all holes for the PS Supplied Expansion Anchors. (Note: Drill all holes to the specifications provided by the expansion anchor's manufacturer.)
- 2.4) Remove all dust and debris created from drilling.
- 2.5) Re-align the Floor Frame with the line and previously drilled holes.
- 2.6) Fasten the Floor Frame to the substrate using the PS Supplied Expansion Anchors.
- 2.7) If more than one section of Floor Frame is needed to complete the run measure the required distance and cut down the next section of Floor Frame if necessary.
- 2.8) Repeat Steps 2.2 through 2.4 for the next section of Floor Frame.
- 2.9) Before fastening the adjacent section of Floor Frame locate (1) of the grooved Alignment Pins .
- 2.10) Slide the grooved end of the Alignment Pin, approximately half of its length, into the alignment pin hole of Floor Frame that has already been fastened. (See Figure 2.2)
- 2.11) Butt the adjacent section of Floor Frame into the previously installed section. Be sure that the Alignment Pin is inserted into the boss of the adjacent section.
- 2.12) Repeat Steps 2.5 through 2.6 for this section of Floor Frame.
- 2.13) Repeat Steps 2.7 through 2.12 as required.
- 2.14) When one side of the Expansion Joint Cover is complete, locate opposite Frame dimension "A" (see chart) from the inside of Frame to inside of Frame as shown in detail above and strike a chalk line at the back side of the Frame. Frames should run parallel with each other.
- 2.15) Repeat Steps 2.3 through 2.13 for the opposing side of the joint.

STEP 3

WING SEAL INSTALLATION

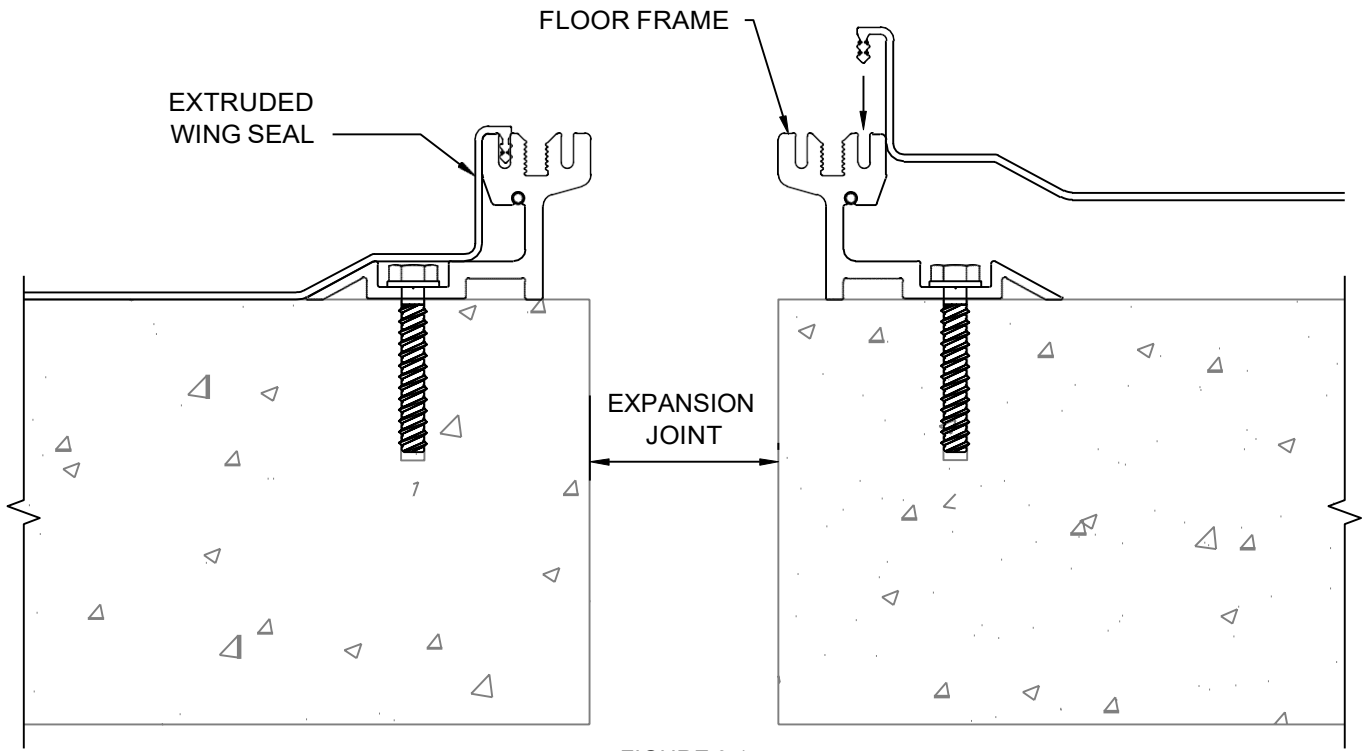

FIGURE 3.1

- 3.1) Locate the PS Supplied Extruded Wing Seal.
- 3.2) The Wing Seal has a "Push-In Arrow" extruded on one side. This Arrow is to be pushed into the slot (furthest away from the expansion joint) on the Floor Frame. (See Figure 3.1) If needed water can be sprayed on the Push-In Arrow to ease installation.
- 3.3) The Wing Seal should be installed on both sides of the joint for the entire run of the PPDA/PPDS cover system. Note: The Wing Seal is flexible so it should lay in place over top of the Floor Frame, however it may need to be held down until it relaxes from its shipping form.
- 3.4) If one length of Wing Seal is not long enough to cover the entire run of joint cover, the Seal will need to be spliced together with an additional section.
- 3.5) In order to splice Wing Seal, butt two sections together and heat weld at the seam with a hot knife or other capable device. (See Figure 3.2)

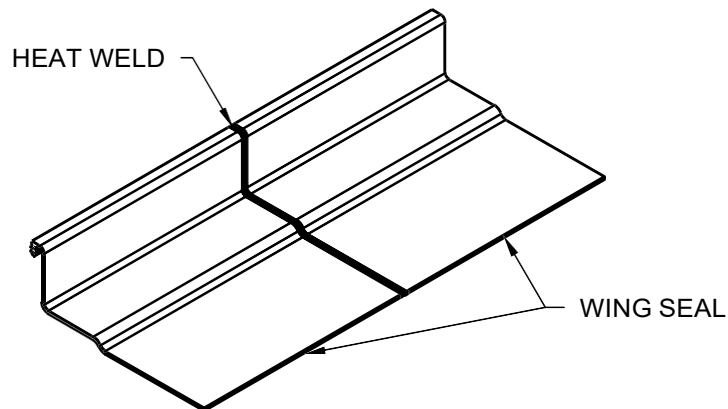

FIGURE 3.2

STEP 3A

WING SEAL INSTALLATION (FOR A BLOCKOUT)

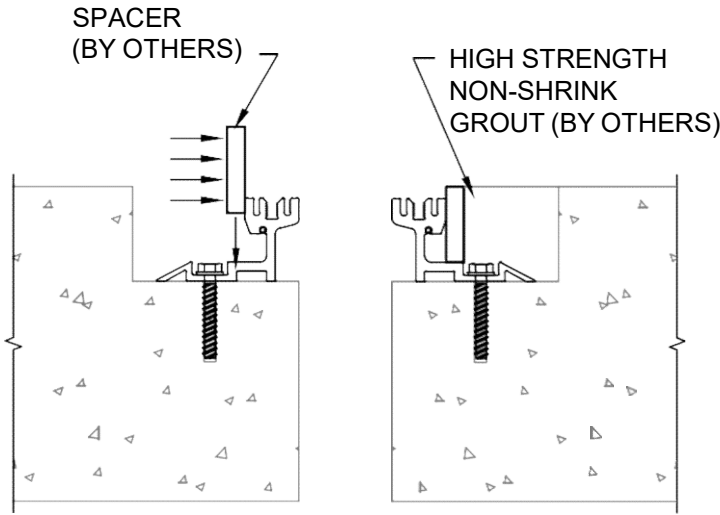

FIGURE 3A.1

Note: When installing a PPDA/PPDS model in a blockout the Wing Seal is installed using an alternate method.

- 3A.1) Install $\frac{3}{8}$ " [9.53mm] wide continuous Spacers (by others) between the Rear Blockout Wall and the Side Frame. The depth of the Spacer will be determined by the depth of the system being installed. Note: The Spacers may need to be greased on the side facing away from the expansion joint to ease removal. (See Figure 3A.1)
- 3A.2) Install High Strength, Non-Shrink Grout (by others) per the manufacturer's guidelines.
- 3A.3) Once Grout (by others) has cured per the manufacturer's guidelines, the Spacers can be removed and discarded.
- 3A.4) Locate the PS Supplied Extruded Wing Seal. The Seal will need to be trimmed to fit in the remaining gap left by the Spacer. The Seal can be trimmed using a straight edge and a utility knife.

- 3A.5) The Wing Seal has a "Push-In Arrow" extruded on one side. This Arrow is to be pushed into the slot (furthest away from the expansion joint) on the Floor Frame. (See Figure 3.A2) If needed water can be sprayed on the Push-In Arrow to ease installation.
- 3A.6) The Wing Seal should be installed on both sides of the joint for the entire run of the PPDA/PPDS cover system. Note: The Wing Seal is flexible so it should lay in place over top of the Side Frame, however it may need to be held down until it relaxes from its shipping form.
- 3A.7) If one length of Wing Seal is not long enough to cover the entire run of joint cover, the Seal will need to be spliced together with an additional section.
- 3A.8) In order to splice Wing Seal, butt two sections together and heat weld at the seam with a hot knife or other capable device. (See Figure 3A.3)

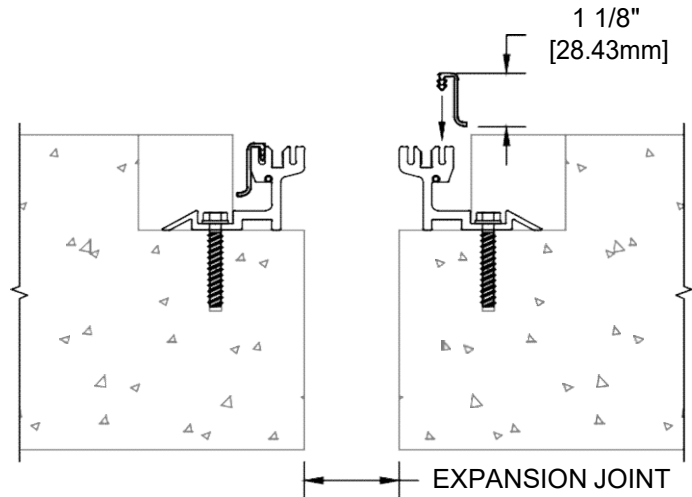

FIGURE 3A.2

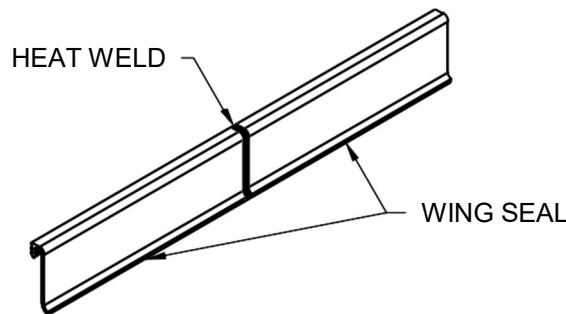
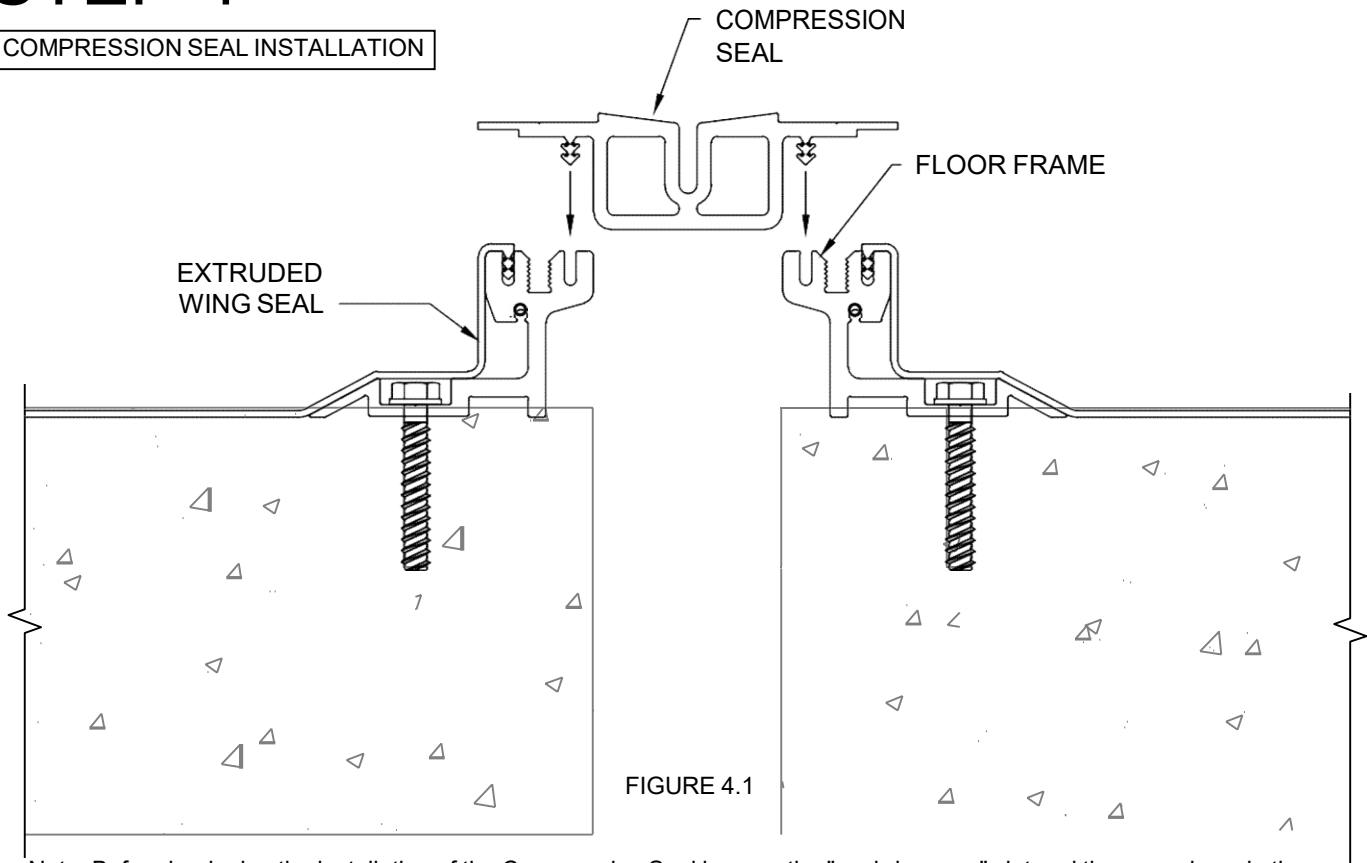

FIGURE 3A.3

STEP 4

COMPRESSION SEAL INSTALLATION



Note: Before beginning the installation of the Compression Seal be sure the "push-in arrow" slot and the screw boss in the Floor Frame are clear of all debris.

- 4.1) Position the PS Supplied Compression Seal over top of the previously installed Floor Frame.
- 4.2) Line up the push-in arrows on the seal with the slots in the Floor Frame. (See Figure 4.1)
- 4.3) Push the Compression Seal into place by forcing the push-in arrows into the Floor Frame slots. The Compression Seal will overlap the previously installed Wing Seals, and it will cover up the extruded screw bosses in the Floor Frame. (See Figure 4.2) **Note:** If needed a wood block and hammer can be used to help seat the push-in arrows into the slots. Also, water can be sprayed on the Push-In Arrow to ease installation.
- 4.4) If one length of Compression Seal is not long enough to cover the entire run of joint cover, the Seal will need to be spliced together with an additional section.
- 4.5) In order to splice Compress seal, butt two sections together and heat weld at the seam with a hot knife or other capable device. (See Figure 4.2)

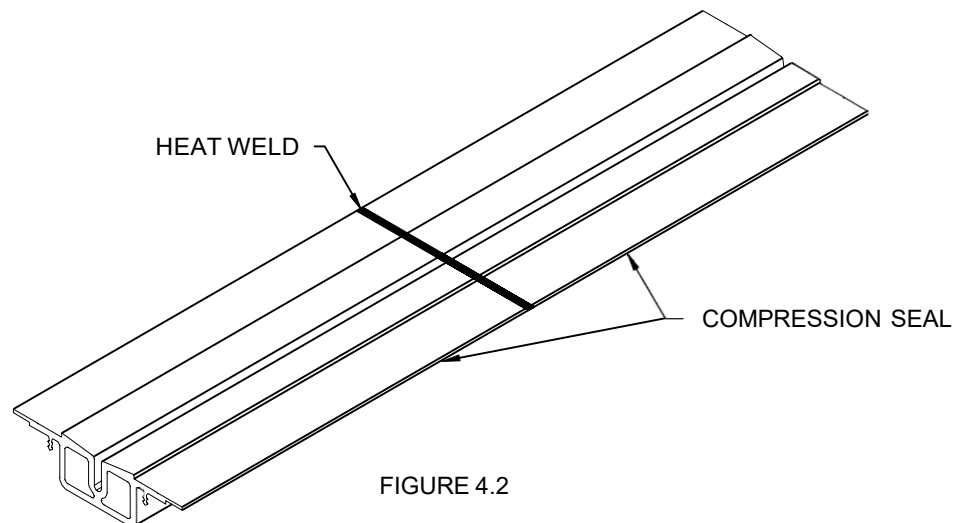

STEP 5

TOP CAP INSTALLATION

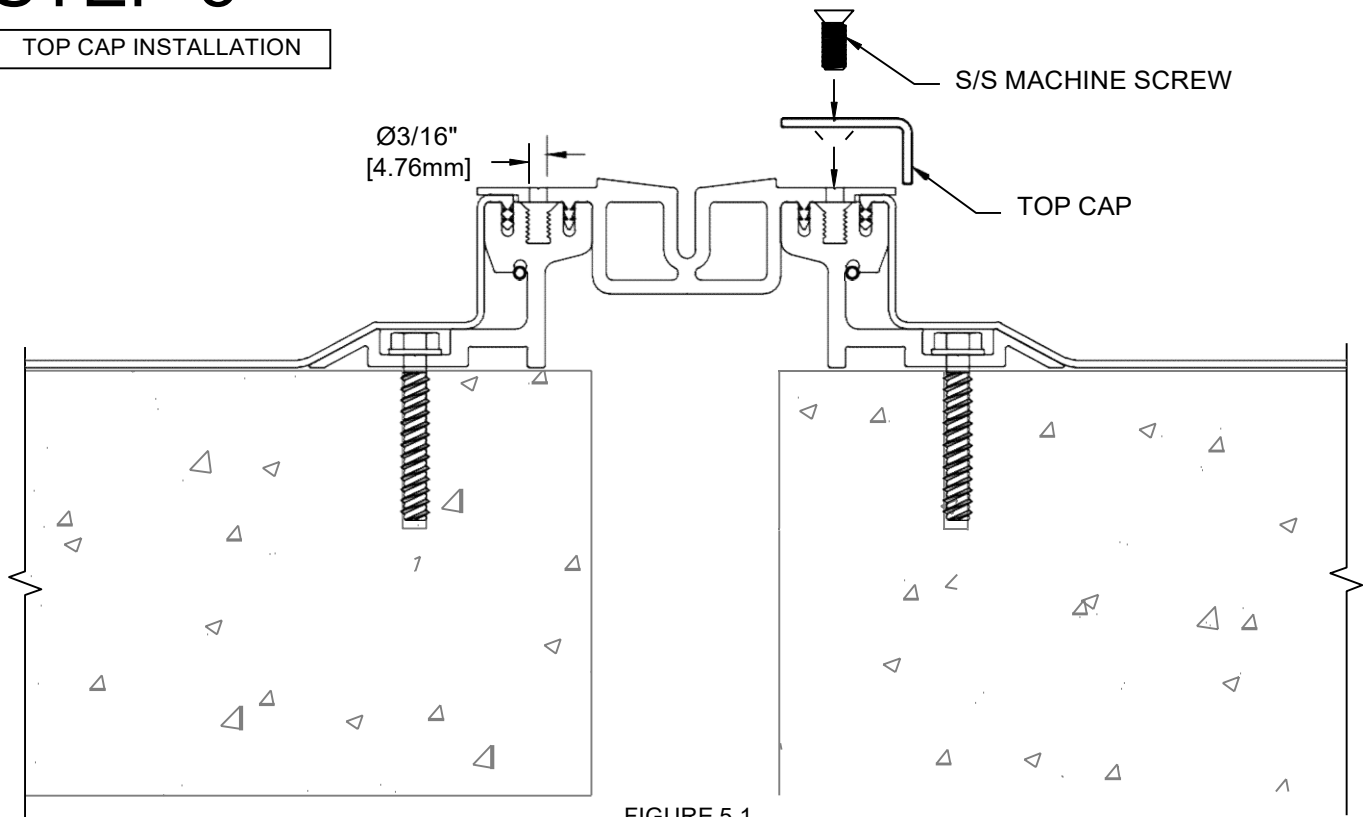

FIGURE 5.1

- 5.1) Locate the PS Supplied Top Caps.
- 5.2) Starting on one side of the joint position the first length of Top Cap in position. Using it as a template, mark the hole locations on the wing of the Compression Seal.
- 5.3) Temporarily remove the Top Cap from the assembly and create $\text{Ø}3/16''$ [Ø4.8mm] clearance holes for the PS Supplied Stainless Steel Machine Screws. (See Figure 5.1)
- 5.4) Reposition the Top Cap on the system and fasten with the PS Supplied Machine Screws. Before tightening screws completely apply a silicone caulk (by others) between the head of the PS Supplied Machine Screws and the countersunk holes in the Top Caps. Be sure to keep the supplied Machine Screws as straight as possible when installing. Failure to do so could result in cross-threading, which will impair the system. (See Figure 5.1)
- 5.5) If more sections of Top Cap are required to finish the run, butt the adjoining sections against the previously install section and repeat Steps 5.2 through 5.4.
- 5.6) Repeat Top Cap installation on the opposite side of the expansion joint.

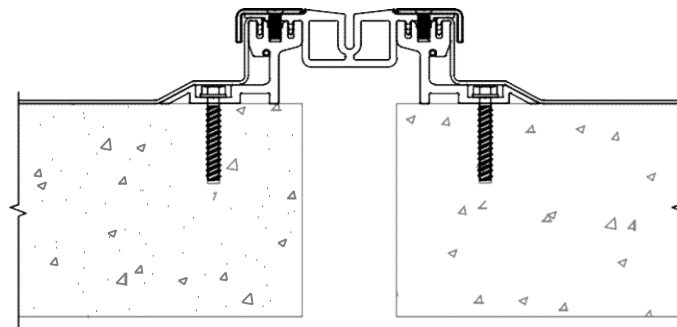

FIGURE 5.2

STEP 6

COMPLETE INSTALLATION

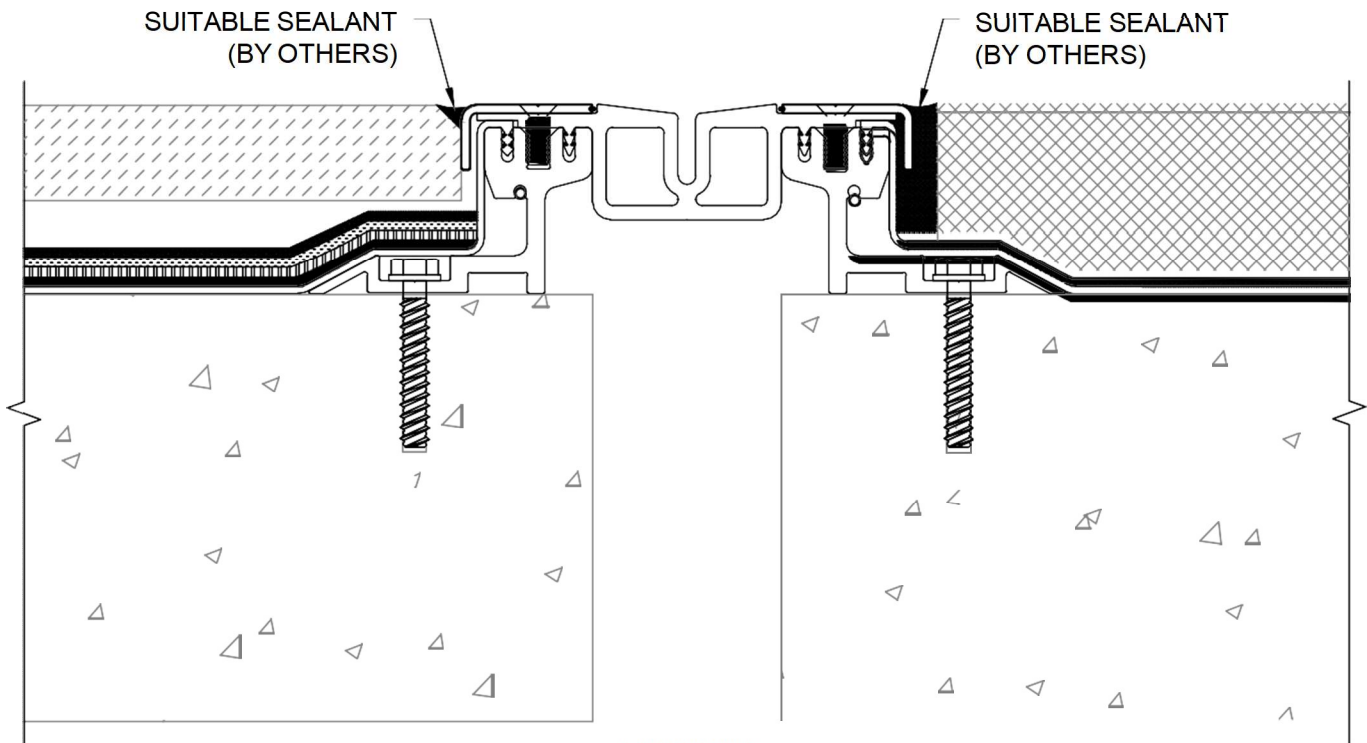

FIGURE 6.1

- 6.1) To complete installation of the PPDA/PPDS system the wing seals need to be tied into the waterproofing of the plazadeck.
- 6.2) There are many ways to tie the wings into the waterproofing, which depends on what kind of waterproofing is being used and what the finished surface of the plaza deck it to be made of. Figures 6.1 and 6.2 show 4 different examples.
- 6.3) The PPDA/PPDS needs to be protected during the installation of the waterproofing, installation of the finished deck surfaces, and until the Architect's final inspection.
- 6.4) If any transitions from floor to floor to floor to wall are included in the run proceed to Step 7.

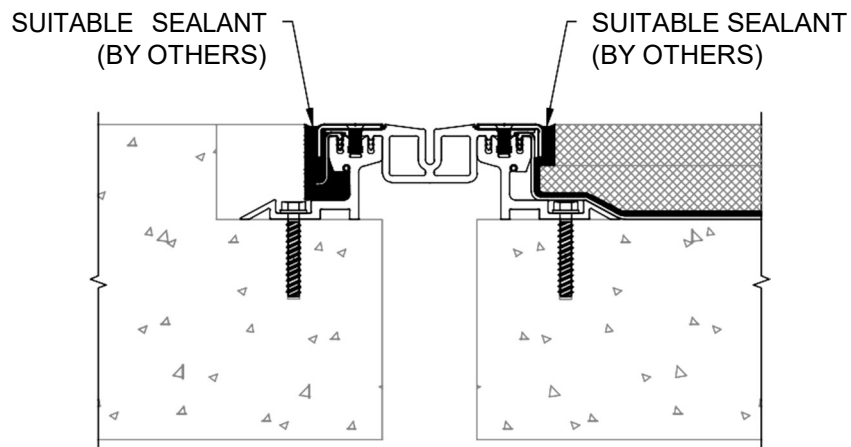

FIGURE 6.2

STEP 7

FLOOR TO WALL INSTALLATION

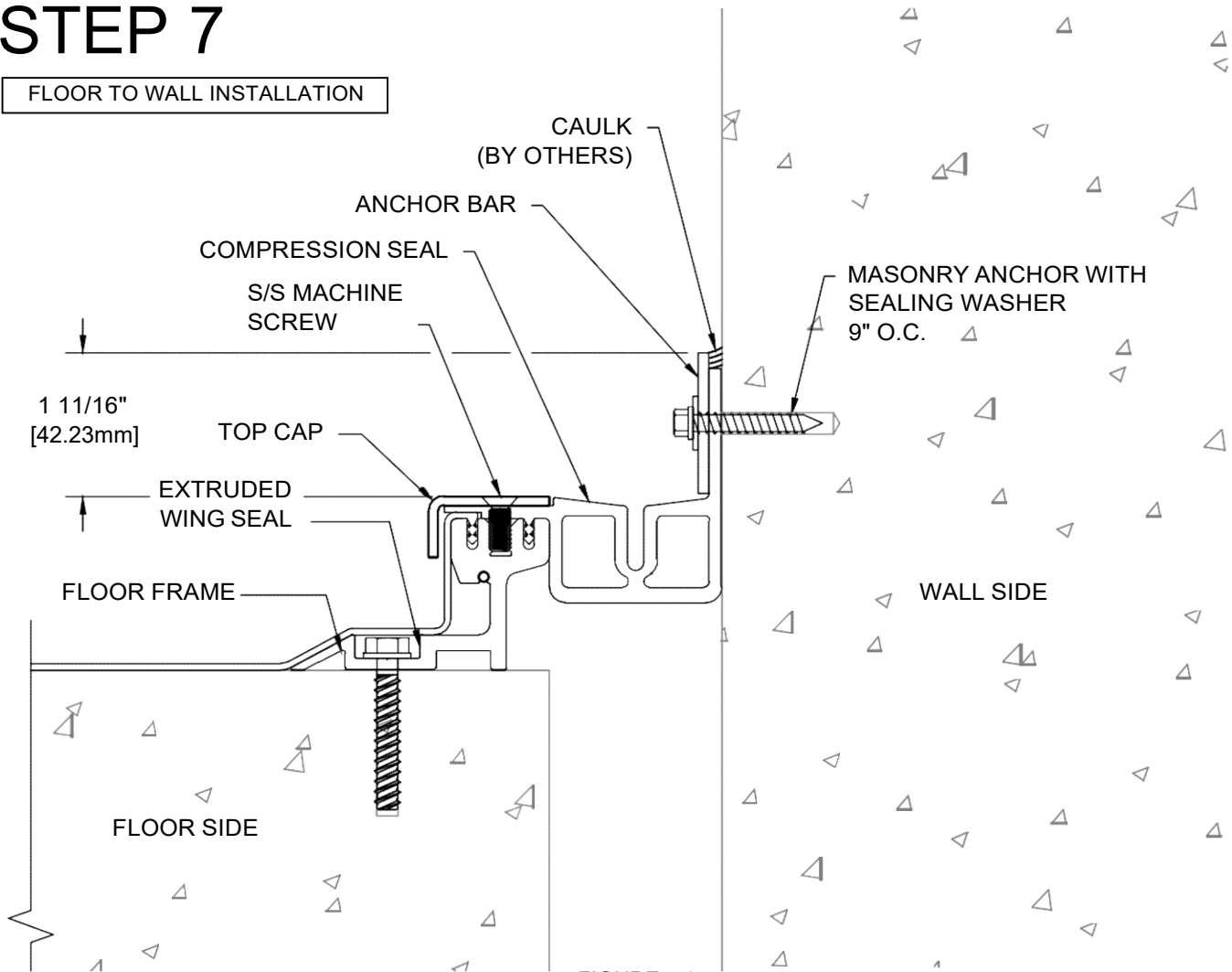

FIGURE 7.1

Note: Typically this model is supplied as a transition from a floor to floor condition to a floor to wall condition. In addition to the steps below the Compression Seal and Wing Seal must be heat welded in the field at the splice location to ensure water tightness.

- 7.1. Prepare surfaces as detailed in Step 1 for the floor side of the PPDaw model.
- 7.2. Install the Floor Frames per Step 2 as required.
- 7.3. Install the Wing Seal per Step 3 or Step 3A as required.
- 7.4. Position the PS Supplied Compression Seal over top of the Floor Frame with the vertical wing against the wall side of the joint.
- 7.5. Line up the push-in arrow on the seal with the slot in the Floor Frame.
- 7.6. Push the Compression Seal into place by forcing the push-in arrows into the Floor Frame slots. The Compression Seal will overlap the previously installed Wing Seals, and it will cover up the extruded screw bosses in the Floor Frame. (Note: If needed a wood block and hammer can be used to help seat the push-in arrows into the slots. Also, water can be sprayed on the Push-In Arrow to ease installation.)
- 7.7. Install the Top Cap on the floor side of the joint per Step 5.
- 7.8. Locate the PS Supplied Anchor Bars.
- 7.9. Position the first length of Anchor Bar so it sits just above the Compression Seal (the top of the anchor bar will be about 1 $\frac{11}{16}$ " [33.47mm] above the top surface of the Top Cap). Using it as a template, mark and drill all holes for the PS Supplied Masonry Anchors. (Note: Drill all holes to the specifications provided by the expansion anchor's manufacturer.)
- 7.10. Reposition the Anchor Bar on the system and fasten with the PS Supplied Masonry Anchors and Sealing Washers.
- 7.11. If more sections of Anchor Bar are required to finish the run, butt the adjoining sections against the previously installed section and repeat Steps 7.8 through 7.10.
- 7.12. After all sections of Anchor Bar are installed seal off the top between the Anchor Bar and wall with an appropriate caulk supplied by others. This completes installation on the wall side of the joint. Continue with installation per Step 6 to complete installation on the floor side of the joint.