

# MODELS PSF/PSC - 600/1000 INSTALLATION INSTRUCTIONS

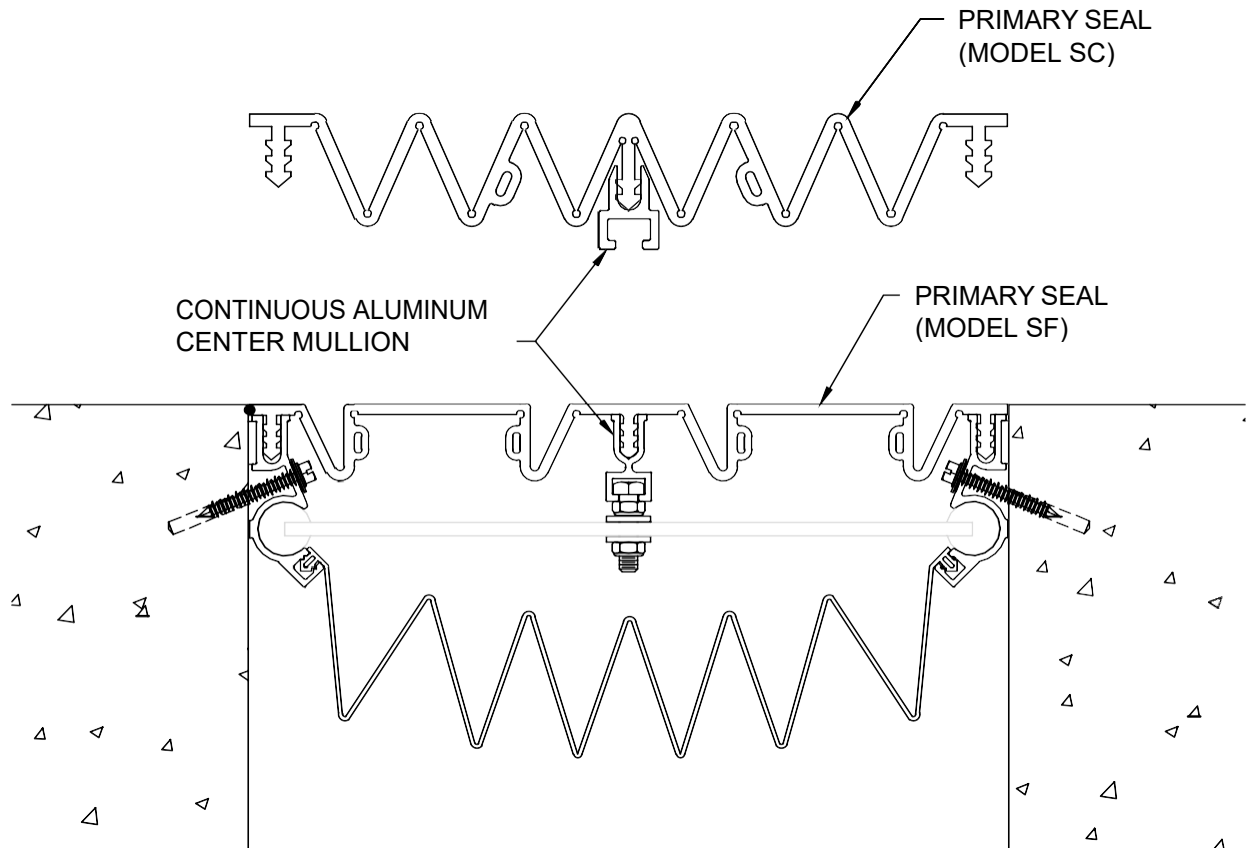

## IMPORTANT INFORMATION

Prior to the commencement of Installation, all materials **MUST** be inspected for Damage. Any damage must be reported to PINNACLE SOLUTIONS, as soon as possible, so that replacement materials may be furnished without delay.

All work must be completed as per Architect's Approved "Shop Drawings", and in accordance with these Installation Instructions. When installation is complete, all materials must be protected from damage until the Architect's FINAL INSPECTION.

All materials should be arranged in the order that they are to be installed. All hardware required for each portion of the work should be placed with the appropriate materials.

Please review all Approved Shop Drawings and this Document to familiarize yourself with all the details and components of this assembly.

### IMPORTANT:

**READ THROUGH ALL INSTRUCTIONS PRIOR TO STARTING INSTALLATION**

# STEP 1

## INSTALLATION OF ALUMINUM TURNBAR FRAMES AND BUTYL TAPE

### Notes:

Before beginning installation, review the architectural drawings and approved Pinnacle Solutions Inc. shop drawings to familiarize yourself with the joint cover models and locations.

Check all of the joint cover components to confirm that the correct joint cover model and size have been received. Also, check for materials that may have been damaged during shipping. Report all incorrect and/or damaged components to PS.

Read through all the steps of these instructions prior to beginning work.

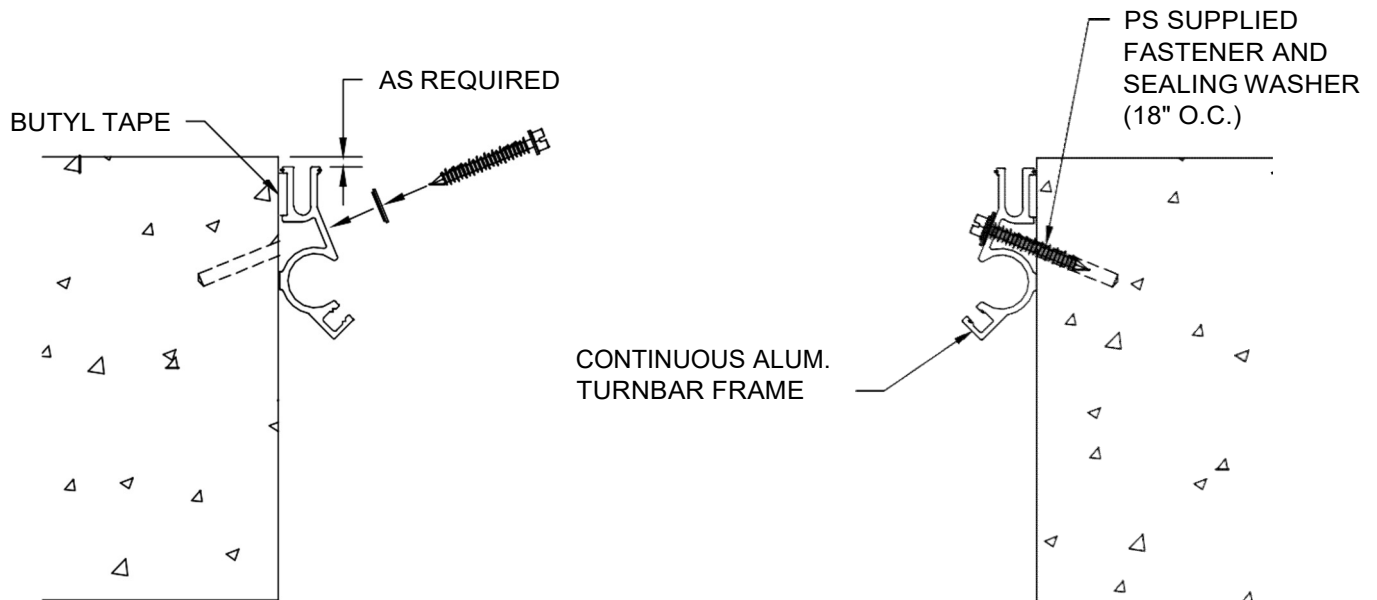

### Step 1:

- 1.) Apply the PS supplied Butyl Tape to the back of the Turnbar Frames.
- 2.) Beginning at one end of the run, start installation of the Frames by peeling the paper backing off of the Butyl Tape and seat the Frames at the appropriate location with the joint.
- 3.) Using the Frame as a template, drill the holes for the PS supplied fasteners and anchor the Frames into the joint.
- 4.) Continue with installation of the Aluminum Frames until all of the Frames, on both sides of the joint, for the entire run are installed.
- 5.) Each Aluminum Frame is double punched to accept either a masonry anchor or a TEK PSCrew with a sealing washer depending on the field condition. All holes that do not receive a fastener and all frame butt joints should be caulked with the PS supplied Sikaflex 1A.

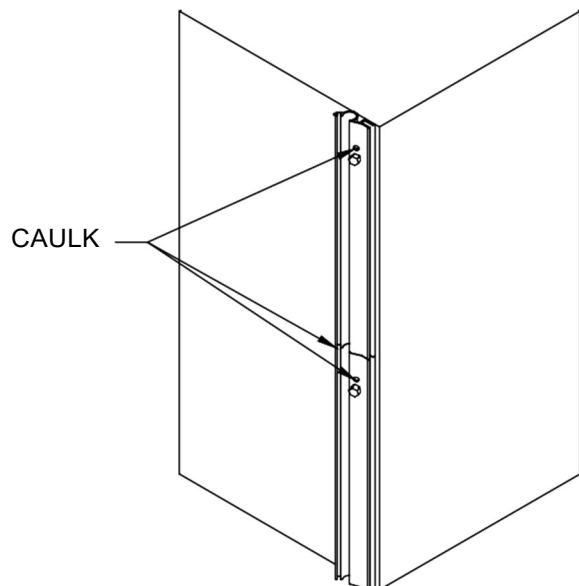

# STEP 1 (Alternate)

## INSTALLATION OF ALUMINUM TURNBAR FRAME WITH ADHESIVE

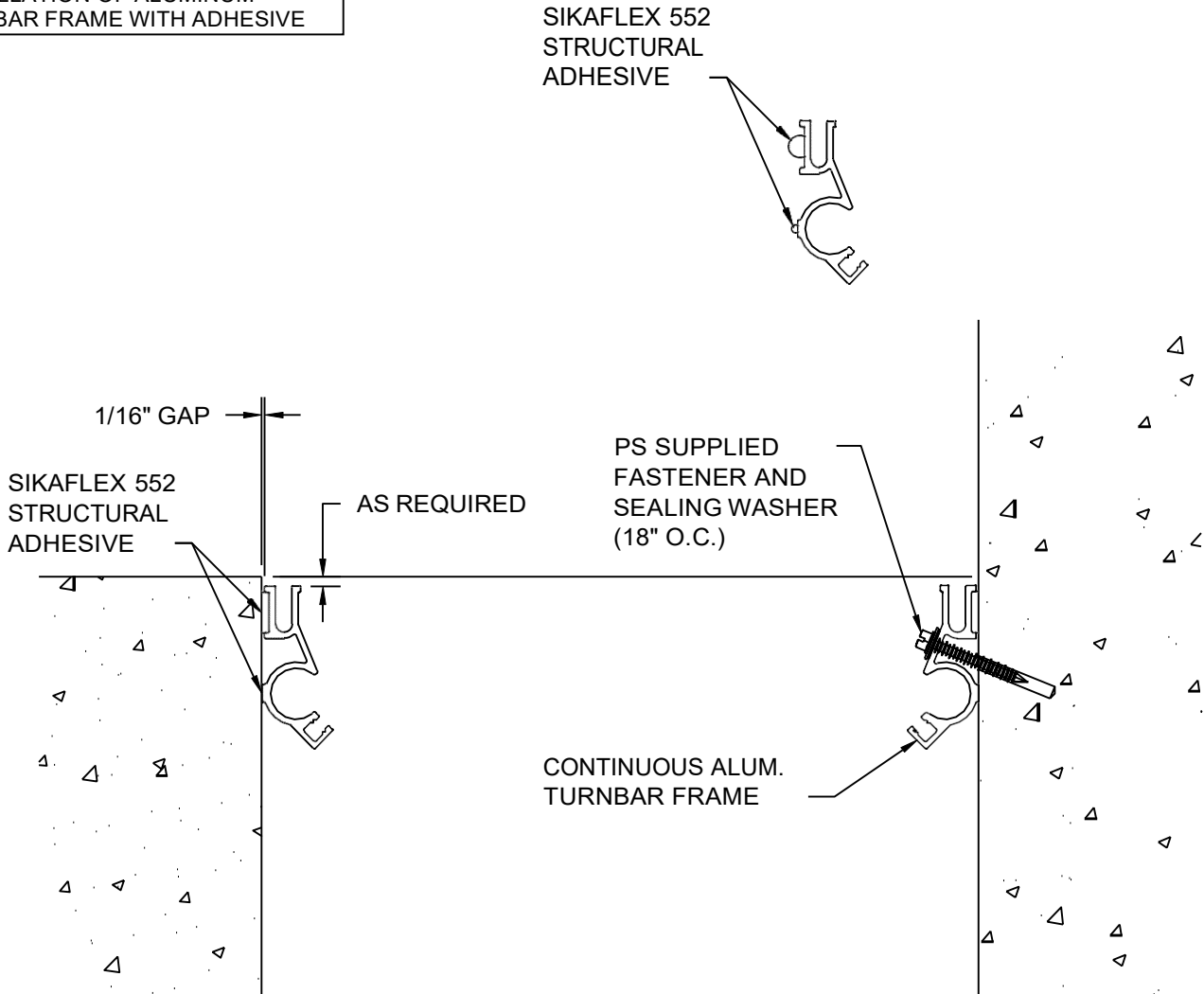

### Step 1 (Alternate):

Note: As some corner wall joint applications, it may not be possible to fit a drill into the joint to drill for mechanical anchors for the frame opposite the wall. For these applications the frame can be installed using a structural adhesive (Sikaflex-552).

- 1.) Assure that the substrate is clean, dry and free from all traces of grease, oil, wax and dust.
- 2.) Wipe down the back side of the Turnbar Frame with soapy water and then with a clean dry cloth.
- 3.) Apply the PS supplied Sikaflex 552 to the back of the Turnbar Frame at the locations shown above. Apply a 1/4" bead to the wider area and a 1/8" bead at the narrower area.
- 4.) Beginning at one end of the run, start installation of the Frames by positioning the Frame at the appropriate dimension back from the joint edge.
- 5.) Seat the Frame against the substrate and apply slight pressure to spread the adhesive and to assure constant contact against the surface. Note: The front edge of the Frames should not be tight to the substrate leaving approximately 1 1/16" gap.
- 6.) Use strips of masking, painters or duct tape, or Styrofoam wedge blocks to hold the Frame in position until the adhesive sets. (Approx. 24 to 48 hours depending on substrate type and temperature.)
- 7.) Repeat for additional Frame lengths as needed.

Note: Refer to the Sikaflex 552 product data sheet for additional application guidelines.

# STEP 2

## INSTALLATION OF SECONDARY SEAL

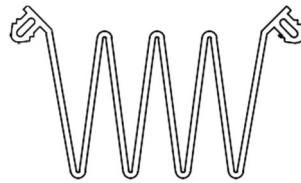

NOTE: (4) CELL SECONDARY SEAL FOR MODELS PSF-600/800 AND PSC-600

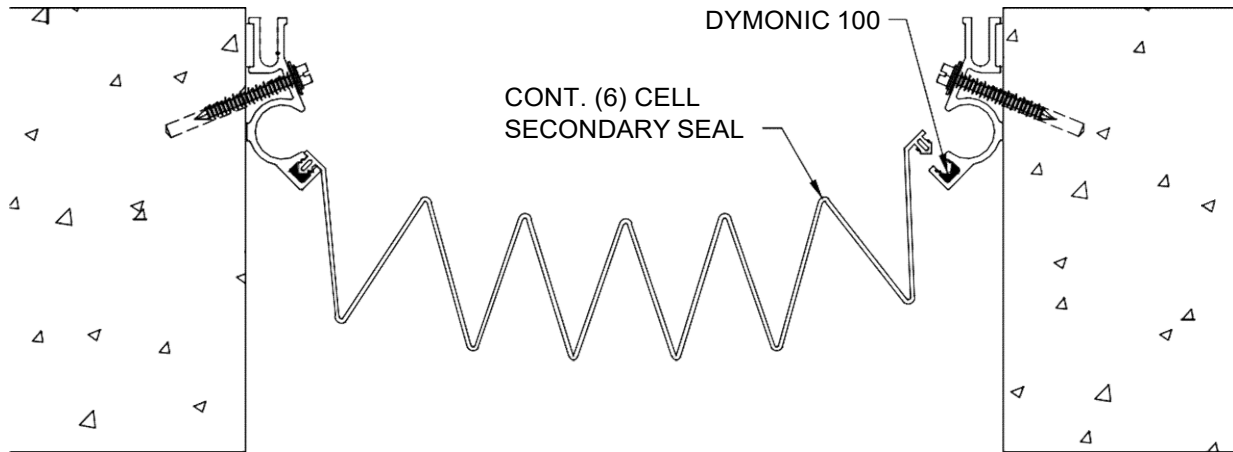

### Step 2:

- 1.) Place a small bead of the C/C supplied Dymonic 100 sealant into the secondary seal receiver slot of each Frame.
- 2.) Starting at the top of the run, install the secondary seal into the Aluminum Frames by pushing the seal tabs into the receiver slots. When required, splice joints in the secondary seal are to be overlapped by 6", top over bottom, and sealed with the Dymonic 100 sealant.

# STEP 3

## TURNBAR ASSEMBLY ATTACHMENT

NOTE: TURNBARS AND CENTER MULLION NOT REQUIRED FOR MODELS PSF-600 AND PSC-600.

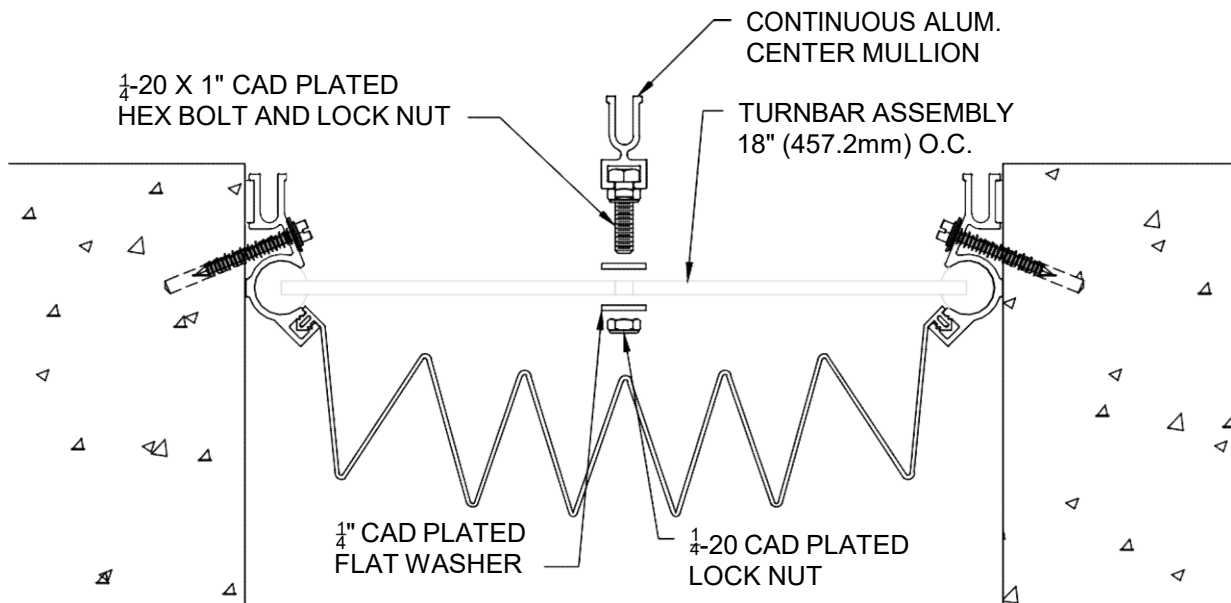

### Step 3:

- 1.) Place the head of a 1/4-20 hex bolt into the slot on the center mullion and slide it into the slot until it is approx. 6" in from the end. Place a 1/4" lock nut onto the bolt and tighten the nut against the center mullion to lock the bolt in position.
- 2.) Place additional 1/4-20 hex bolts into the slot of the center mullion and position them at approx. 18" o.c. using 1/4" locknuts, lock the bolts in position.
- 3.) Slide turnbar assemblies into the turnbar frames. (Quantity to equal the number of hex. bolts in the center mullion.)
- 4.) Place a flat washer on each hex bolt, insert each bolt through the center hole of a turnbar assembly, place another flat washer and locknut on each bolt. Note: The locknuts should only be tightened until the washers are snug against the turnbar as the turnbars must be free to pivot with joint movement. (See Step 6 for splicing instructions.)

# STEP 5

## PRIMARY SEAL INSTALLATION

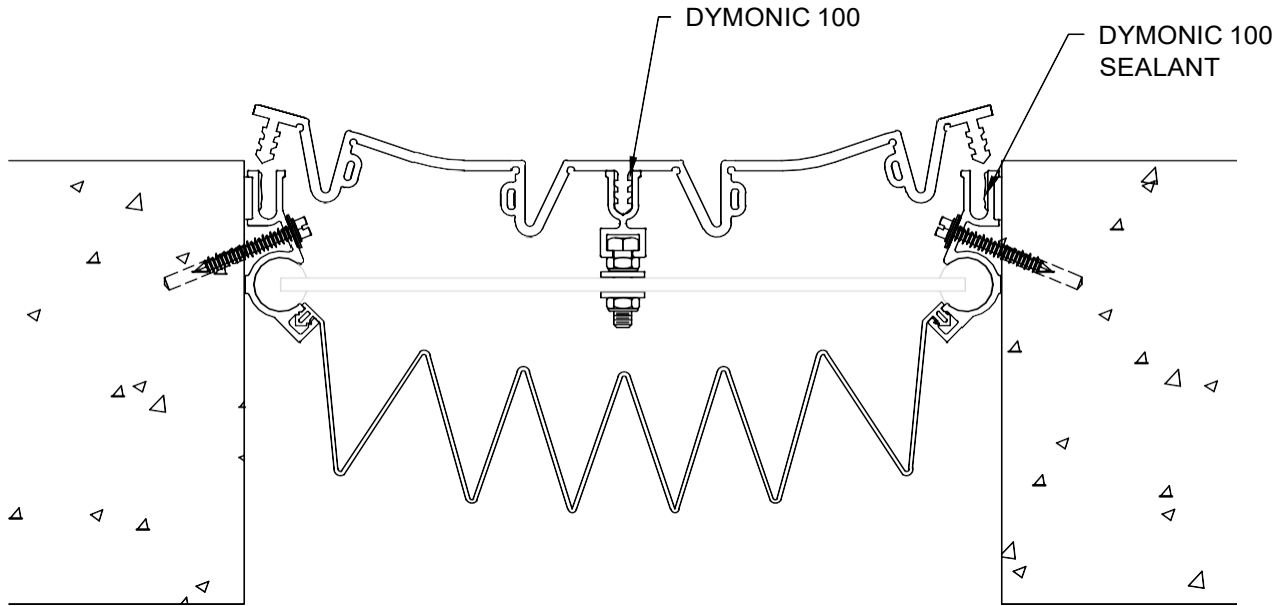

### Step 4:

- 1.) Prior to installation of the primary seal, place a 1/8" to 3/16" bead of Dymonic 100 sealant into the primary seal receiver slot of each Aluminum Frame. Note: Application of the sealant will aid in the installation of the seal and will improve the water resistance of the cover.
- 2.) Cut the Primary Seal to length as needed for the run. (See Step 5 for cutting and splicing instructions) When necessary, multiple lengths of seal may have to be spliced together for the required length of the run.
- 3.) Starting at the top of the run, install the Primary Seal into the Center Mullion and then into the side frames by pushing the Seal tabs into the receiver slots (See detail above). If necessary, you may use a rubber mallet and a wood block to gently seat the Primary Seal flush with the surface of the retainer.

# STEP 6

## CUTTING AND SPLICE DETAILS

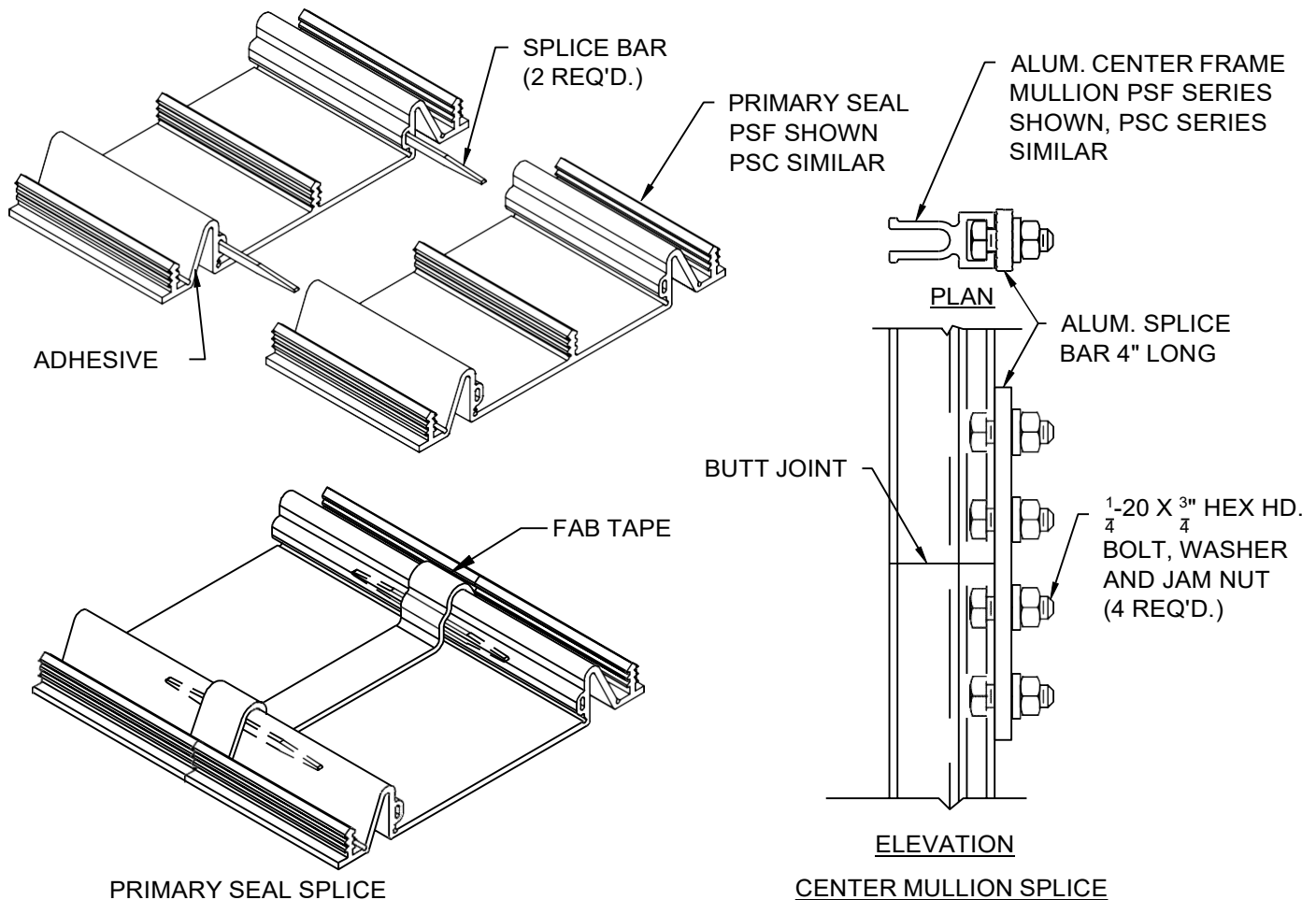

### Step 5: CUTTING

- 1) Determine the length of seal required for the applicable area and measure and mark the seal.
- 2) Place the seal with the location to be cut into a miter box and flood the gasket area to be cut with water to lubricate the saw blade.
- 3) Using a hacksaw and the PS supplied serrated hacksaw blade, make the cut using long strokes while applying downward force when cutting. The cut should be made with as few strokes as possible in order to prevent a ragged end on the seal.

### SPLICING

- 1) Wipe surface of the Splice Bars and the ends of the seals to be bonded with alcohol (or similar) to remove all dirt, moisture, and oils that might affect the bond.
- 2) When appropriate, apply the 3M PSCotch Weld adhesive to half of each Splice Bar. Insert only the portion of the bar with adhesive into the splice bar slot of one of the seals. **IMPORTANT: PLEASE OBSERVE THE SAFETY PRECAUTIONS ON THE ADHESIVE CONTAINER!**
- 3) Apply the 3M PSCotch Weld adhesive to the entire cut surface of the Seal and the remaining portion of the Splice Bar.
- 4) Align the two ends of each Seal, insert the Splice Bar into the opposite seal and bring the ends of the seal together. Apply pressure against the ends of the seals until the adhesive has set.
- 5) Once the Adhesive has cured, cut a piece of the Fab Tape that is wide enough to span across the entire width of the backside of the seal splice. Place the tape so that it is centered over the butt joint and press the tape firmly against the back of the seal working the tape into all voids to create a watertight seal.

### CENTER MULLION SPLICE

- 1) Place (4) 1/4-20 x 3/4" hex bolts through the 4" long splice bar. loosely place a 1" flat washer and jam nut onto each bolt.
- 2) Insert the heads of two bolts into the top end of one center mullion and the other two bolts into the bottom of the adjacent center mullion.
- 3) Butt the end of the center mullions together and tighten the nuts.